



DIVISIONE ELETTRONICA E SISTEMI

---

# **SCK4N-D**

**AUTOMATIC SYNCHRONISING RELAY**

**USER MANUAL**

**P503D802**

**April 2005**



## INDEX

1	GENERAL CHARACTERISTICS .....	1
1.1	VOLTAGE CHECK – DEAD BUS operating mode .....	4
1.2	SYNCHRO - CHECK operating mode .....	5
1.3	SYNCHRONIZER operating mode .....	7
2	FRONT PANEL KEYS .....	10
3	FRONT PANEL LED SIGNALLING .....	11
4	PROGRAMMING AND TEST .....	12
4.1	How to program the protection relay .....	12
4.2	How to modify a visualized parameter .....	13
4.3	Reset .....	13
4.4	Test of output relays .....	14
5	DISPLAY AND PROGRAMMING .....	15
5.1	Standard display .....	15
5.2	Visualization structure .....	17
5.3	Operating modes (fig. 1) .....	20
5.4	Address and time (fig. 1) .....	20
5.5	Nominal values set-up (fig. 1) .....	21
5.6	General set-up (fig. 2) .....	22
5.7	Set-up VOLTAGE CHECK DEAD BUS - LT .....	24
5.8	Set-up SYNCHRO-CHECK - PS .....	26
5.9	Set-up - SYNCHRONIZER - PA .....	28
5.10	Output relays programming (fig. 2) .....	34
5.11	Digital inputs function programming (fig. 2) .....	36
5.12	Special function programming (fig. 2) .....	38
5.13	Signals visualization (fig. 3) .....	39
5.14	Events (fig. 3) .....	42
5.15	Trip counters (fig. 3) .....	46
6	INSTALLATION .....	48
6.1	Supplied kit .....	48
6.2	Cabling .....	49
6.3	Relays R3 and R4 - Signalling / Command set-up .....	52
6.4	RS485 serial communication port .....	53
7	TECHNICAL CHARACTERISTICS .....	54
8	TABLE .....	55

*Information printed in this manual subject to change without prior notice.*

*This manual must not be reproduced in whole or in part, in any form or by any means without the express written permission of SEB Divisione Elettronica e Sistemi.*

# 1 GENERAL CHARACTERISTICS

The unit SCK4N-D performs functions as automatic synchronizing and coupler device (jointly with the CU90N for voltage equalizing) and as synchro-check relay in high voltage or medium voltage systems.

The user can select one or more of the functional modes listed below:

Functions	ANSI
Voltage check - dead bus - LT	25
Synchro-check - PS	25
Synchronizer - PA	25

Under all functional modes the unit measures two voltages (the reference voltage **Ur** and the controlled voltage **Uc**) and depending on the selected functional mode, from the programmed parameters and the parameters of the measured voltages (voltage difference, phase-angle, voltage slipping etc.) the unit deliver the closing command to the circuit breaker or the commands to the speed governor of a generator (only when Synchronizer mode is selected).

All the functions of the unit are fully programmable by front panel keyboard or through a RS485 serial interface using a personal computer with set-up program; furthermore the relay can be programmed through a remote control and monitoring system.

**OPERATING MODES** - the SCK4N-D unit manages the following functional modes:

- voltage check - dead bus (LT)
- synchro-check (PS)
- automatic synchronizer (PA)

It can be selected one or more operating modes; in the last case the selection of the operating mode is done automatically by the unit as function of the measured parameters.

Specifically, the selection between the **LT** operating mode and the **PS** or **PA** operating modes is guaranteed by appropriate constraints between the thresholds of voltage absence/presence used by the **LT** mode and the threshold of minimum voltage difference used by **PS** and **PA** modes.

The selection between the **PS mode** and the **PA mode** is based on the measurement of the voltage slipping between the measured voltages **Ur** and **Uc**.

It is possible to define each measured voltage available (U1, U2, U3, U4) as reference voltage (**Ur**), controlled voltage (**Uc**) or no functions (OFF).

Therefore it is possible to have more than one measured voltage for reference voltage **Ur** or controlled voltage **Uc** and to enable or disable the measuring channels (U1, U2, U3, U4) using an external command (digital input).

The closing command can be delivered directly to the circuit breaker (impulsive command) or to a control unit which will manage the closing command to the circuit breaker (continue command as closing enable signal).

The programmable values of the thresholds are listed in Table A.

**OUTPUT RELAYS** - the SCK4N-D unit controls 4 output relays (named R1, R2, R3 and R4); these relays can be programmed to be activated on START or TRIP conditions of one or more thresholds.

START	instantaneous activation of the output relay when at least one of the measured voltages exceeds the programmed threshold value (e.g. voltage presence <b>U&gt;</b> , voltage difference <b>DUs&lt;</b> etc.)
TRIP	activation of the output relay to deliver closing command to the circuit breaker or TRIP related to threshold <b>U&gt;&gt;</b> .

The quiescent state of each single relay R1, R2, R3 and R4 can be programmed as normally energized (ON) or normally de-energized (OFF).

An additional relay R5 (normally energized) is controlled by the self-diagnosis routines to report detected fault conditions.

Partial and total counters of the output relay activation (on TRIP conditions or closing command delivered to the circuit breaker) are available.

**DIGITAL INPUTS** - there are available 3 digital inputs to activate the following functions (when enabled by the programmed set-up):

- additional time delay on circuit breaker closing commands
- on/off operating modes
- on/off thresholds
- on/off commands to the speed governor
- selection of voltages (reference and controlled)
- STATUS function (recording of measures on external event)
- pilot wire fault monitoring (DIG2 only)
- temporary operations

For each digital input can be programmed the condition that activates the related functions:

HI voltage =	> 20 V dc / ac
LO voltage =	0 ÷ 10 V dc / ac

The digital input acquisition is valid when the voltage value stays in the range HI or LO for at least 40 ms.

**DISPLAY OF MEASURES** - the user can select the continuous display of a measured parameter such as:

- reference voltage or controlled voltage
- frequency of the reference voltage or of the controlled voltage
- voltage difference
- phase angle between the measured voltages
- slipping between the measured voltages
- derivative slipping between the measured voltages

**EVENTS** - information related to the last 6 events (TRIP or COMMAND delivery or STATUS) are recorded in the EEPROM memory.

Information includes the measured parameters, the programmed parameters, the digital input status, date and time of the event.

**SELF-DIAGNOSIS** - the software includes a continuous monitoring module that controls the functionality of all hardware and software resources of the protection relay.

Detected fault conditions are reported by:

- diagnostic message on the display
- glow of a red LED on front panel
- R5 output relay drop-off

The fault condition signalling stays until faults are pointed out by the monitoring module; during this condition the protection functions are suspended to avoid unsuitable command delivery.

**STATUS FUNCTION** - when the STATUS function is activated by one of the digital input (when programmed) the SCK4N-D unit memorizes information related to measured voltages and digital input status (see par. 5.14 - EVENTS). The recorded information allows an analysis of trip causes in co-operative protection relays systems.

**PILOT WIRE FAULT MONITORING** - when the function is programmed, the digital input DIG2 is used to control the correct functionality of the pilot wire. Digital input DIG2 is always expected to be complementary of DIG1 input (HI-LO or LO-HI) to identify faults on pilot wire.

The fault condition is reported as detected by the self-diagnosis module but the protection functions are not suspended; only the functions related to DIG1 digital input are suspended as the DIG1 status cannot be longer considered as true.

The fault condition is reported when DIG1 and DIG2 signals are not complementary for more then 100 ms.

**REMOTE COMMUNICATION** - the opto-insulated serial port RS485 can communicate with a personal computer or a remote control and monitoring system equipped with an RS485 interface or with a standard RS485/RS232 converter.

It is possible to select the communication standard between STANDARD (ASCII 7 bit - Seb protocol) or MODBUS (ASCII mode, SLAVE).

All the set-up and measured parameters can be transmitted on the RS485 communication serial port; when communication is active (LED REMOTE glows), the operator on front panel can visualize the relay set-up but changes of parameters are disabled (ENTER and  buttons disabled).

## 1.1 VOLTAGE CHECK – DEAD BUS operating mode

This operating mode is used to connect two electrical systems (bus-bars or lines) of which at least one of them is dead (without voltage)

No synchro-check functions are performed; it is performed only a check of absence/presence of voltages. The issue of the closing command to the circuit breaker (paralleling) is provided with a programmable time delay to avoid unsuitable command issue.

When one of the measured voltages exceeds a programmable threshold, the operation will be disabled.

When the unit is programmed as the **voltage check - dead bus** operating mode it will measure 2 voltages, one named **Ur** (reference voltage) and one named **Uc** (controlled voltage); the two voltages can be line voltages or phase voltages.

The SCK4N-D unit compares both voltages with three programmable thresholds:

voltage absence threshold	U<
voltage presence threshold	U>
overvoltage threshold (function inhibition)	U>>

Three functional modes can be selected:

- |    |                    |  |   |
|----|--------------------|--|---|
| 1) | <b>LT Ur&gt;</b>   | paralleling in presence of only <b>Ur</b> voltage      | ( <b>Ur&gt; Uc&lt;</b> - rif. <b>E2LT</b> ) |
| 2) | <b>LT Uc&gt;</b>   | paralleling in presence of only <b>Uc</b> voltage      | ( <b>Ur&lt; Uc&gt;</b> - rif. <b>E3LT</b> ) |
| 3) | <b>LT Ur,c&lt;</b> | paralleling in absence of both <b>Ur</b> and <b>Uc</b> | ( <b>Ur&lt; Uc&lt;</b> - rif. <b>E4LT</b> ) |

With reference to the above functional modes, for each mode the condition to start (**starting condition**) the time delay **Tlt** (definite time) and the issue of the paralleling command when the time delay expire are the followings:

- |    |                  |   |   |
|----|------------------|---|---|
| 1) | <b>LT Ur&gt;</b> | Ur presence [Ur > (U>)] (overcoming threshold U>) | Uc absence [Uc < (U<)] (overcoming threshold U<)  |
| 2) | <b>LT Uc&gt;</b> | Ur absence [Ur < (U<)] (overcoming threshold U<)  | Uc presence [Uc > (U>)] (overcoming threshold U>) |

- 3) **LT Ur,c<**    Ur absence [Ur < (U<)]    (overcoming threshold U<)  
                           Uc absence [Uc < (U<)]    (overcoming threshold U<)

In the programming session it is possible to enable each of the functional modes.

If one or both the measured voltages overcome the threshold **U>>**, the SCK4N-D unit will disable the issue of the paralleling command.

The user can select the paralleling command mode as pulse command (programmable length **Tcom**) or as continuous command (as long as the start conditions are present); in the last case the duration of the command is equal to **Tcom** at least.

When the starting condition disappears or when the pulse command is issued, the time delay **TIt** is reset.

Only when the pulse command mode is selected, if the paralleling condition are still present after a command issue, a new paralleling command will be issued after a time delay **TIt**.

In pulse command mode, when the paralleling condition are present, **TIt** represents the time delay before the issue of the first command and the time delay between two consecutive paralleling commands. The issue of consecutive paralleling commands must be disabled by using an external control signal (digital input) from the circuit breaker (circuit breaker closed – paralleling operation completed) or to enable the paralleling operation for a definite time period (see paragraph 5.12 – Special functions).

By using an external command (digital input) it is possible to increase of **TAIt** seconds the programmed time delay **TIt**.

NOTE: in the programming session the SCK4N-D unit verifies that:

the threshold value	<b>U&lt; must be less than - U&gt; / 1.2</b>
the threshold value	<b>U&gt;&gt; must be greater then - 1.2 * U&gt;</b>

When one or more of the above conditions are not verified, an error message will be displayed at the end of the programming session.

## 1.2 SYNCHRO - CHECK operating mode

This operating mode is used to connect two electrical systems (bus-bars or lines) both energized.

The SCK4N-D unit verifies the synchronism condition and the voltage difference between the voltages of the two electrical systems; the issue of the closing command to the circuit breaker (paralleling) is provided with a programmable time delay to avoid unsuitable command issue.

When one of the measured voltages exceeds a programmable threshold, the operation will be disabled.



When the unit is programmed as **synchro-check** operating mode it will measure 2 voltages, one named **Ur** (reference voltage) and one named **Uc** (controlled voltage); the two voltages can be line voltages or phase voltages.

The SCK4N-D unit compares the voltages with the following programmable thresholds:

<b>Ur</b>	voltage presence threshold	<b>U&gt;</b>
	overvoltage threshold (function inhibition)	<b>U&gt;&gt;</b>
<b>Uc</b>	overvoltage threshold (function inhibition)	<b>U&gt;&gt;</b>

If one or both the measured voltages overcome the **U>>** threshold, the paralleling command issue will be disabled.

From the measurement of the 2 voltages the unit will compute (in absolute value):

- the voltage difference  $|DU|$
- the phase angle between the voltages  $|\Phi|$
- the voltage slipping  $|S|$

To start (**starting condition**) the time delay **Tps** (definite time) and to allow issue of the paralleling command when the time delay expire ALL the followings must be verified (at the same time):

- 1) **Ur** present (overcoming threshold **U>**)  
**Ur > (U>)**
- 2)  $|DU| < |DU_s|$  (overcoming threshold  $|DU_s| <$ )
- 3)  $|\Phi| < |\Phi_s|$  (overcoming threshold  $|\Phi_s| <$ )
- 4)  $|S| < |S_s|$  (overcoming threshold  $|S_s| <$ )

The user can select the paralleling command mode as pulse command (programmable length **Tcom**) or as continuous command (as long as the start conditions are present); in the last case the duration of the command is equal to **Tcom** at least.

When the starting condition disappears or when the pulse command is issued, the time delay **Tps** is reset.

Only when the pulse command mode is selected, if the paralleling condition are still present after a command issue, a new paralleling command will be issued after a time delay **Tps**.

In pulse command mode, when the paralleling condition are present, **Tps** represents the time delay before the issue of the first command and the time delay between two consecutive paralleling commands. The issue of consecutive paralleling commands must be disabled by using an external control signal (digital input) from the circuit breaker

(circuit breaker closed – paralleling operation completed) or to enable the paralleling operation for a definite time period (see paragraph 5.12 – Special functions).

By using an external command (digital input) it is possible to increase of **TAps** seconds the programmed time delay **Tps**.

NOTE: if the operation mode LT (voltage check – dead bus) is also enabled, in the programming session the SCK4N-D unit verifies that:

$$\text{programmed threshold} \quad |DU_s| \text{ must be } \leq 0.8 * [(U>) - (U<)]$$

When the above condition is not verified, an error message will be displayed at the end of the programming session.

### 1.3 SYNCHRONIZER operating mode

This operating mode is used to connect a synchronous generator to an electrical system (bus-bars or lines)

The SCK4N-D unit verifies the synchronism condition and the voltage difference between the voltages of the two electrical systems; the issue of the closing command to the circuit breaker (paralleling) is provided with a programmable time delay to avoid unsuitable command issue.

When one of the measured voltages exceeds a programmable threshold, the operation will be disabled.

To avoid excessive stress to the generator, the closing command signal to the circuit breaker is delivered with lead condition ( $\Phi_{ant}$  lead angle) computed as function of the voltage slipping **S** and of the circuit breaker operating time **Tmnv** in order to close the circuit breaker poles on the synchronism condition.

The SCK4N-D unit compares the voltages with the following programmable thresholds:

<b>Ur</b>	voltage presence threshold	<b>U&gt;</b>
	overvoltage threshold (function inhibition)	<b>U&gt;&gt;</b>
<b>Uc</b>	overvoltage threshold (function inhibition)	<b>U&gt;&gt;</b>

If one or both the measured voltages overcome the **U>>** threshold, the paralleling command issue will be disabled.

From the measurement of the 2 voltages the unit will compute (in absolute value):

- the voltage difference  $|DU|$
- the phase angle between the voltages  $|\Phi|$
- the voltage slipping  $|S|$
- the voltage slipping derivative  $|dS/dt|$

To start (**starting condition**) the time delay **Tpa** (definite time) and to allow issue of the paralleling command when the time delay expire ALL the following conditions must be verified (at the same time):

- 1)  $U_r$  present  
**Ur > (U>)** (overcoming threshold **U>**)
- 2)  $|DU| < |DUa|$  (overcoming threshold  $|DUa| <$ )
- 3)  $|S| < |Sa|$  (overcoming threshold  $|Sa| <$ )
- 4)  $\left| \frac{dS}{dt} \right| < \left| \frac{dSa}{dt} \right|$  (overcoming threshold  $|dSa| <$ )

An additional condition to allow the issue of the paralleling command (programmable command length **Tcom**, issued when the lead angle between the two voltages is equal to **Φant**) is the following:

- 5)  $\frac{d|\Phi|}{dt} < 0$  (the phase angle between the voltages is decreasing)

The threshold  $|dSa| <$  is computed by using the formula:

$$dSa < = Ks * (Tk - Tmnv - 0.04)$$

where:

<b>Ks</b>	programmable constant
<b>Tk</b>	time base (programmable)
<b>Tmnv</b>	circuit breaker operating time (programmable)

Note: the threshold  $|dSa/dt| <$  can be disabled.

By using an external command (digital input) it is possible to increase of **TApa** seconds the programmed time delay **Tpa**.

When the starting condition disappears or when the pulse command is issued, the time delay **Tps** is reset.

If the paralleling condition are still present after a command issue, a new paralleling command will be issued after a time delay **Tpa**.

When the paralleling condition are present, **Tps** represents the time delay before the issue of the first command and the time delay between two consecutive paralleling commands. The issue of consecutive paralleling commands must be disabled using an external control signal (digital input) from the circuit breaker (circuit breaker closed – paralleling operation completed) or to enable the paralleling operation for a definite time period (see paragraph 5.12 – Special functions).

NOTE

If the operation mode **PS** (synchro-check) is also enabled, in the programming session the SCK4N-D unit verifies that:

$$(|S_a|<) > 1.2 * (|S_s|<)$$

and the overcome of the threshold  $|S_s|<$  enables the **PS** operating mode instead of **PA** operating mode.

If the operation mode **LT** (voltage check – dead bus) is also enabled, in the programming session the SCK4N-D unit verifies that:

$$\text{programmed threshold } |DU_a| \text{ must be } \leq 0.8 * [(U>) - (U<)]$$

When the above conditions are not verified, an error message will be displayed at the end of the programming session.

### Generator speed governor commands

Two output relays can be programmed to deliver commands to the speed governor of the generator (**AUM** - accelerate, **DIM** - decelerate) as function of the negative or positive sign of the voltage slipping or, under specific condition, as function of the phase angle between the measured voltages.

The commands length **Treg** is programmable; they are issued with time cadence **Ti** (programmable) until the threshold  $|S_a|<$  is overcome (voltage slipping small enough).

The time cadence **Ti** of the command issue can be programmed as time definite or time dependent (as inverse function of the voltage slipping).

The issue of commands to the speed governor **is forced** when both the  $|S_x|<$  and  $|\Phi_x|>$  threshold are overcome (programmable thresholds); these thresholds are defined to avoid stand-by conditions of the paralleling system in presence of a large phase-angle when the voltage slipping is zero or very low (very long time to wait the paralleling condition).

This functionality is automatically disabled when the (**PS + PA**) and (**LT + PS + PA**) operating mode are selected.

These forced command are issued with **Tx** time delay (programmable, time definite).

The issue of commands to the speed governor can be inhibited when the absolute value of the voltage slipping overcomes a programmable threshold  $|S_m|>$ ; the inhibition function can be disabled through the keyboard or by using an external signal (digital input).

The time delay between two consecutive commands cannot be shorter than a time delay **Tim** (programmable) to guarantee the proper acquisition by the speed governor.

If one or both the measured voltages overcome the **U>>** threshold, the speed governor command issue will be disabled.

## 2 FRONT PANEL KEYS

The 5 push-buttons on the front panel allow to visualize all the protection parameters and to modify the protection set-up.



right arrow



down arrow



programming session activation or parameter confirmation



change or increment of the selected parameter



reset of the protection relay (ref. par. 4.3)

### VISUALIZATION OF PARAMETERS

- all visualizations are circular and they can be displayed using the two arrow push-buttons.
- the structure of the visualizations and their contents are showed in Figures 1, 2 and 3.
- when the sealable transparent front panel is installed only the arrow push-buttons and the RESET push-button are accessible to prevent unauthorized modification of the protection set-up.

### MODIFICATION OF PARAMETERS

- remove the transparent sealable front panel to access ENTER and  push-buttons.

### 3 FRONT PANEL LED SIGNALLING

POWER (green) ⊕ auxiliary supply available

FAIL (red) ⊕ fault condition detected by SELF-DIAGNOSIS software or by PILOT WIRE FAULT MONITORING function

REMOTE (red) ⊕ communication session active on RS485 port

LT U>> (red) ⊕ issue paralleling command with Voltage-check dead bus mode and/or trip threshold U>>

PS U>> (red) ⊕ issue paralleling command with Synchro-check mode and/or trip threshold U>>

PA U>> (red) ⊕ issue paralleling command with Synchronizing mode and/or trip threshold U>>

The last trip condition (threshold indication) is also showed on front panel display; more information on trip condition are presented in the recorded EVENT (see par. 5.14).

## 4 PROGRAMMING AND TEST

The SCK4N-D unit is easily programmable following the instructions in the next paragraphs:

- HOW TO PROGRAM THE PROTECTION RELAY
- HOW TO MODIFY A VISUALIZED PARAMETER

All parameters can be freely modified; the proper protection set-up as required by the plant management is submitted to the operator's judgment.

### 4.1 How to program the protection relay

The programmable parameters are showed in Figures 1, 2 and 3 at the following references:

B2÷B6	relay address (RS485) and date/time
C1÷C4	nominal values, display etc.
D1÷D5	general set-up
E1LT÷E8LT	set-up voltage-check dead bus mode (LT)
E1PS÷E7PS	set-up synchro-check mode (PS)
E1PA÷E16PA	set-up synchronizing mode (PA)
F1÷F16	output relays functions
G1÷G3	digital input functions
H1-H2	special functions
R1÷R20	partial trip counters reset

The programming sequence is the following:

- 1) **SELECT** the visualization (on display) of the parameter to be modified using the arrow push-buttons
- 2) **ACTIVATE** the PARAMETER MODIFICATION session depressing the [ENTER] push-button and modify the parameter value
- 3) **END** the parameter modification session depressing again the [ENTER] push-button
- 4) **REPEAT** the procedure from 1) to 3) for all the parameters required to obtain the new unit set-up
- 5) **CONFIRM** the new protection relay set-up at the visualization CONFIRM PROG? (Fig. 1, ref. J1) within 5 minutes depressing the push-buttons [ENTER],  up to visualize **YES** and [ENTER] again to confirm.

NOTE: The unit will continue to operate using the previous set-up until the new set-up is confirmed as at point 5) above; the visualization of the modified parameters before the new set-up confirmation is only temporary to allow an easy definition of the new set-up.

If the new set-up is not confirmed within 5 minutes from the last pressed push-button, the SCK4N-D unit visualizes again the previous set-up (the parameters set-up that the unit is still using).

## 4.2 How to modify a visualized parameter

When the parameter to be modified is visualized on front panel display do the following sequence:

- 1) **PRESS [ENTER]** to activate the parameter modification session

If one or more parameters are modifiable, on the first of them will appear a blinking cursor.

If no parameters are modifiable, no blinking cursor will appear.

- 2) **MODIFY THE PARAMETER** pressing the arrow push-buttons and 



when two parameters are modifiable, the push-button allows to point-out the parameter to be modified (the selected parameter will blink)



when numerical parameters are pointed-out the push-button allows to select the digit to be modified



increasing of the parameter

- a) the digits are increased by 1 unit
- b) the other parameters are presented following the selection list

- 3) **PRESS [ENTER]** to end parameter modification session

The modification session is ended and the parameter stops to blink

NOTE: if a numerical parameter is selected out of the accepted range (as shown in Table A) when the push-button [ENTER] is pressed for few seconds an error message will be displayed as:

Data
Error

and the parameter will be displayed again with the former value.

## 4.3 Reset

When the push-button [RESET] is pressed, the unit returns to the standard condition:

- reset of glowing LEDs



- drop-off of tripped relays
- reset of any parameter changed but not confirmed (parameters are shown as confirmed at the end of the last programming session)
- display on STANDARD MODE (Fig. 1, ref. A1 - par. 5.1)

#### 4.4 Test of output relays

When the output relays test is selected (Fig. 2, ref. F16) it is possible to command an output relay (one at the time) to trip from the current status allowing functional tests on electrical plants.

The output relays are activated with the following sequence:

- 1) **SELECT THE VISUALIZATION** of the desired output relay to be tested

TEST R1
OFF

- 2) **PRESS [ENTER]** to activate the test session; the message OFF will start to blink.

- 3) **PRESS**  and the message on the display will change as:

TEST R1
ON

- 4) **PRESS [ENTER]** to command the instantaneous trip of the output relay (change of the current status).

The relay will stay on the new condition until:

- the  or **[RESET]** push-button is pressed
- the **[ENTER]** push-button is pressed and the sequence at points 3) and 4) is repeated (presenting OFF condition)

The same procedure will be used for R2, R3 and R4 relays.

## 5 DISPLAY AND PROGRAMMING

The contents and the structure of the displayed messages are shown in figures 1, 2 and 3; the references A1, B1, B2 etc. identify specific displayed messages in the figures.

### 5.1 Standard display

#### A1 - STANDARD DISPLAY

It is the standard displayed message without operator's intervention (no push-buttons pressed for at least 5 minutes) or when the RESET push-button has been pressed.

The displayed information is function of the unit status.

#### NORMAL FUCTIONING

During this state the following information can be visualized (as defined by set-up):

- **Protection function (ANSI code)** - the display shows the code ANSI 25
- **Measured voltages and parameters** - the display shows one of the measured parameters (voltages or related parameters); the information to be visualized is selected by operator (ref. C3) and it is function of the selected operative mode.

#### PARALLELING COMMAND ISSUE

When a paralleling command is issued (or when the U>> threshold is overcome) the unit visualizes a TRIP message that includes the operating mode related to the issued paralleling command (as more than one operating mode can be programmed as active) or the threshold related to the trip; the displayed messages are as the following:

TRIP PA	TRIP PS	TRIP U>>	TRIP LT
------------	------------	-------------	------------

The information of the trip, as well the glowing of the related LEDs, is displayed until the [RESET] push-button is pressed.

If a new trip condition occurs, the displayed information will be updated; information related to previous trips are recorded in EVENTS memory.

#### FAULT CONDITION

When a permanent or temporary fault condition is detected by the self-diagnosis module, the following message is displayed:

FAIL eeeeeeee
------------------

The string eeeeeeee can be:

F.PILOT      Detected fault condition on pilot wire; the function related to DIG1 digital input is suspended  
**Corrective action** - verify pilot wire (short or open circuit)

HARDWARE Detected fault condition on hardware or software resources of the protection relay; all functions are suspended.  
**Corrective action** - replace the unit and contact SEB post sales service

### 5.2 Visualization structure

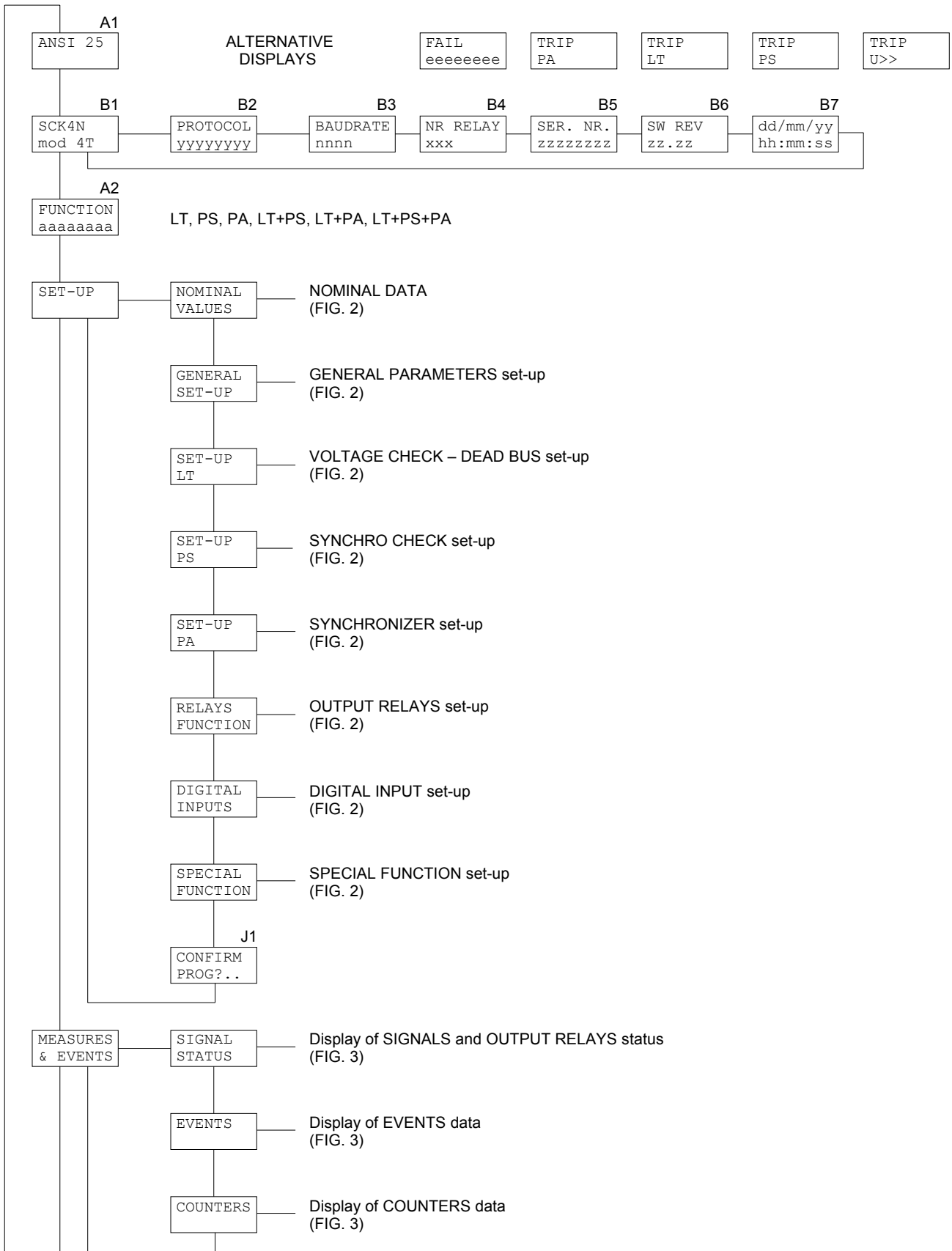

Figure 1

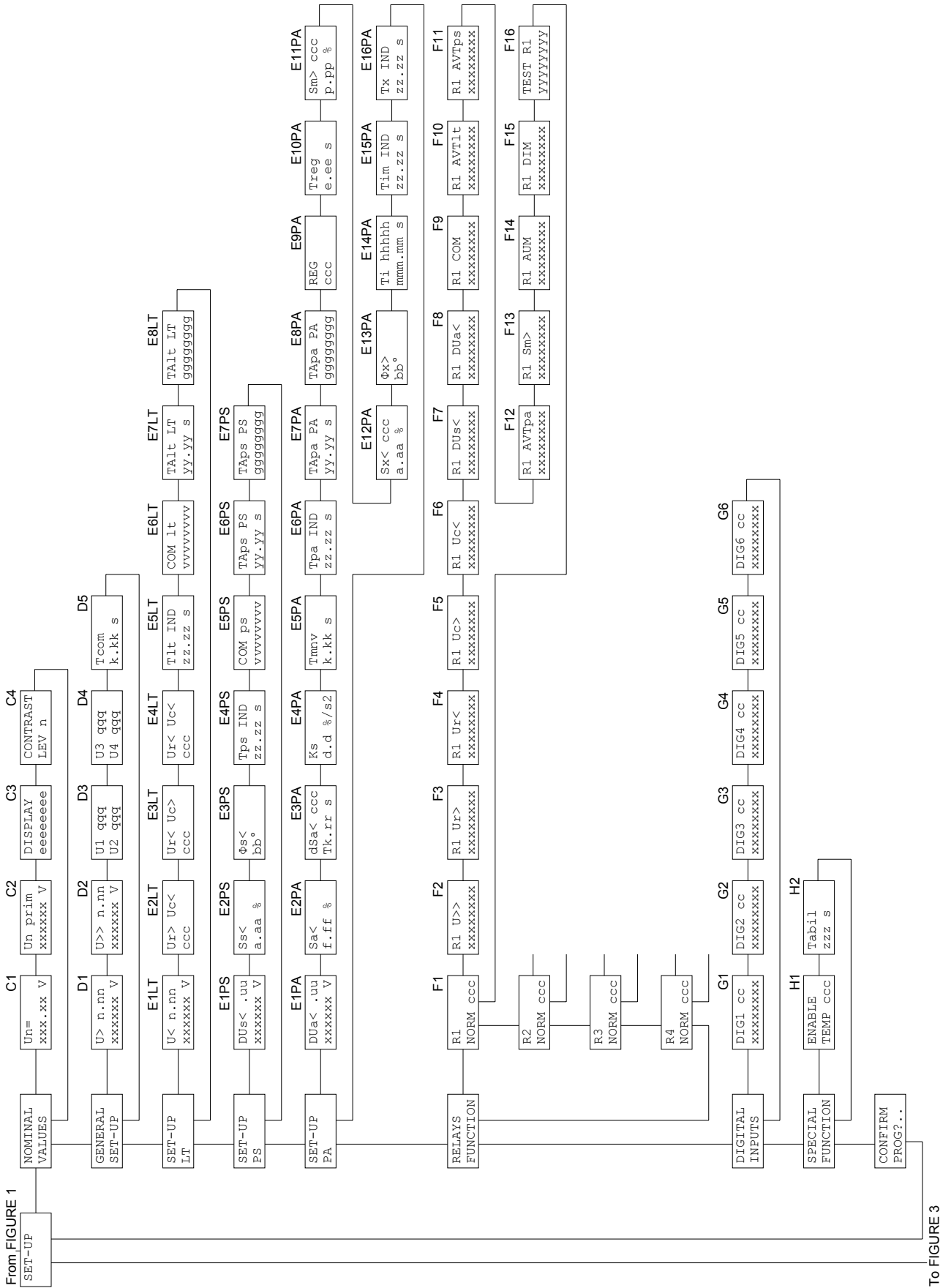

Figure 2

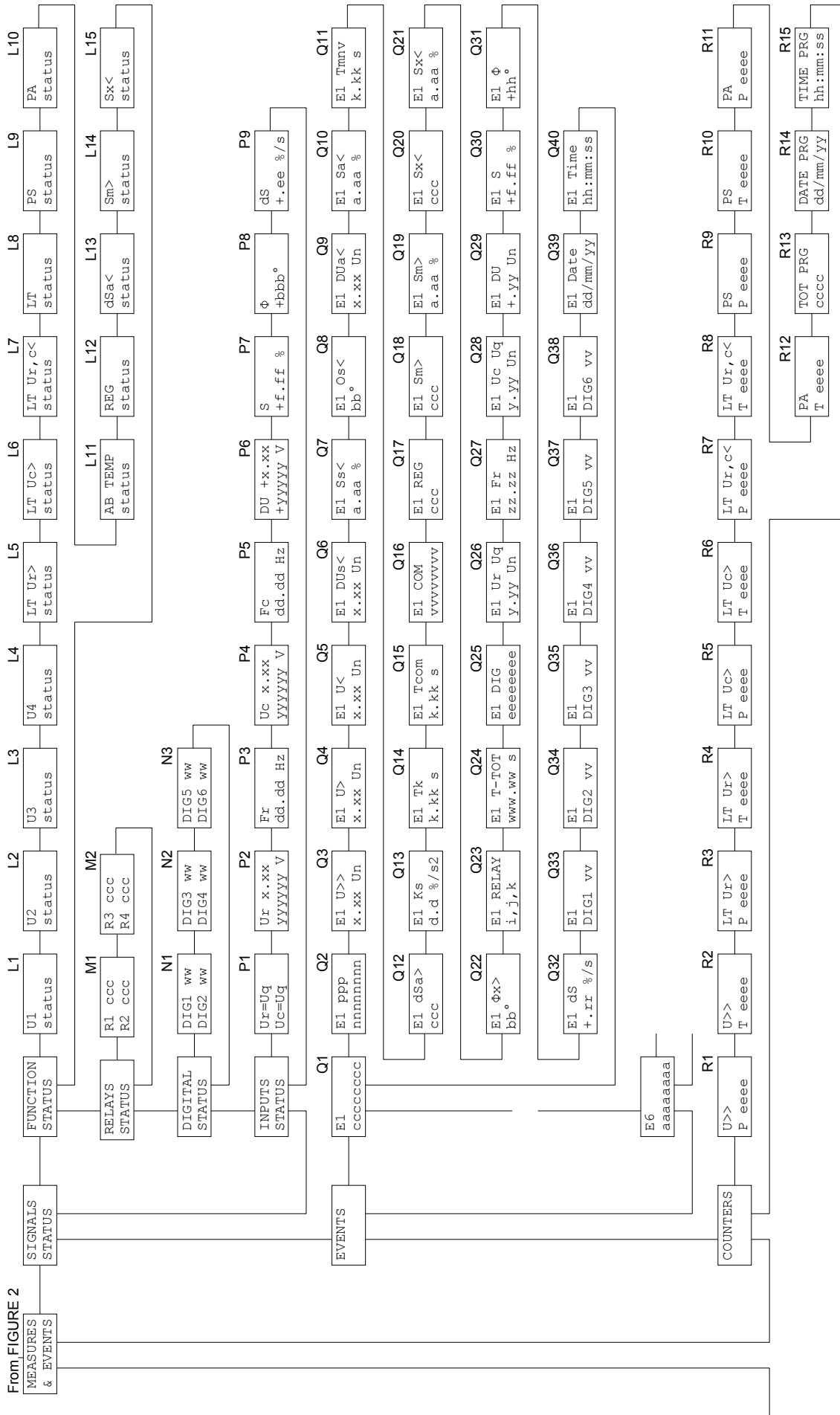

Figure 3

### 5.3 Operating modes (fig. 1)

#### A2 - OPERATING MODE SELECTION (programmable)

FUNCTION aaaaaaaa
----------------------

Selection of the operating modes of the SCK4N-D unit.

The available selections (parameter aaaaaaaaa) are the following:

LT	VOLTAGE-CHECK DEAD BUS (ref. par. 1.1)
PS	SYNCHRO CHECK (ref. par. 1.2)
PA	SYNCHRONISING (ref. par. 1.3)
LT+PS	VOLTAGE CHECK and SYNCHRO-CHECK operating mode
LT+PA	VOLTAGE CHECK and SYNCHRONIZING operating mode
PS+PA	SYNCHRO CHECK and SYNCHRONIZING operating mode
LT+PS+PA	VOLTAGE CHECK and SYNCHRO-CHECK and SYNCHRONIZING operating mode

### 5.4 Address and time (fig. 1)

#### B1 - RELAY MODEL (not programmable)

SCK4N-D mod. 4T
--------------------

#### B2 - COMMUNICATION PROTOCOL (programmable)

**B2**

PROTOCOL xxxxxxxx
----------------------

The communication protocol is programmable between the followings:

STANDARD	ASCII SEB protocol
MODBUS	Modbus protocol (SLAVE)

When the MODBUS protocol is selected the following display is showed to allow the selection of the transmission speed:

**B3**

BAUDRATE xxxx
------------------

The xxxx parameter is selectable between the followings:

**300 - 600 - 1200 - 2400 - 4800 - 9600**

When the STANDARD protocol is selected the baud rate is automatically selected by the protection relay.

#### **B4 - ADDRESS (programmable)**

NR RELAY 001
-----------------

Programmable address from 001 to 255.

The number is used on RS485 port to address a specific unit when two or more unit or protection relays are linked on the same serial line.

#### **B5 - RELAY SERIAL NUMBER (not programmable)**

SER. NR 0012345
--------------------

#### **B6 - SOFTWARE REVISION LEVEL (not programmable)**

SW REV zz.zz
-----------------

#### **B7 - TIME / DATE (programmable)**

dd/mm/yy hh:mm:ss
----------------------

Time and date are programmable and they are used to mark recorded events.

NOTE the clock is not provided with back-up battery, therefore a loss of auxiliary supply will force time/date to the following condition:

01/01/90 00:00:00
----------------------

### **5.5 Nominal values set-up (fig. 1)**

#### **C1 - NOMINAL LINE VOLTAGE SELECTION - Un (programmable)**

Un = xxx.xx V
------------------

**Un:** nominal line voltage selection (nominal secondary voltage of plant VTs) selectable between the followings:

**57,73 - 63,50 - 72,16 - 100 - 110 - 125 - 190 - 220 - 230 - 380 - 400**

#### **C2 - PRIMARY VTs LINE VOLTAGE (programmable)**

U prim xxxxxx V
--------------------



Primary voltage value of the installed line VT's; the value is programmable from 000001 to 999999 V.

### C3 - STANDARD DISPLAY SELECTION (programmable)

```
DISPLAY
eeeeeeee
```

It allows to select the standard displayed information (ref. A1) when no trip condition occurs and no fault condition have been detected by the self-diagnosis module.

The available selections are the following:

ANSI	displays of ANSI code
Ur	displays measured reference voltage
Uc	displays measured controlled voltage
Fr	displays frequency of the reference voltage
Fc	displays frequency of the controlled voltage
DU	displays the difference between Ur and Uc voltages
ANGOLO	displays the phase-angle between Ur and Uc voltages
S	displays the slipping between Ur and Uc voltages
dS	displays the slipping derivative

The voltages are shown in primary values (as function of the set-up at ref. C2)

Selection examples:

```
DISPLAY
ANSI
```

```
DISPLAY
Fr
```

```
DISPLAY
dS
```

### C4 - DISPLAY CONTRAST LEVEL (programmable)

```
CONTRAST
LEV x
```

The display contrast level is programmable from 0 to 9.

The backlighted display is switched off if no push-button is pressed for at least 5 minutes; when one of the front panel push- button is pressed the display is switched on.

## 5.6 General set-up (fig. 2)

### D1 - VOLTAGE PRESENCE THRESHOLD (programmable)

```
U> n.nn
xxxxxx V
```

**n.nn:** threshold value expressed as Un

**xxxxxx:** threshold value expressed as Volt

The overcome of the threshold means presence of the voltage. For the programmable values please refer to table A.

**D2 - OVERVOLTAGE THRESHOLD (programmable)**

U>> n.nn xxxxxx V
----------------------

**n.nn:** threshold value expressed as Un

**xxxxxx:** threshold value expressed as Volt

The overcome of the threshold **disables the operations** of SCK4N-D unit (paralleling command issue or commands to the speed governor). For the programmable values please refer to table A.

The SCK4N-D unit verifies that the **U>>** threshold value must be programmed at least **1.2 times** the value of the **U>** threshold. If the condition is not verified, an error message will be displayed during the programming session (at CONFIRM programming – ref. 4.1).

**D3 - D4 SELECTION OF THE MEASURED VOLTAGES (programmable)**

U1 qqg U2 qqg
------------------

U3 qqg U4 qqg
------------------

Selection of the measured voltages (referred to the input transducers U1, U2, U3 and U4, see insertion scheme)

**qqg** can be programmed

Ur reference voltage

Uc controlled voltage

OFF no functions

More than one input transducer can be programmed for the same function, to allow paralleling operation in different points of the installation; in this case the proper operating voltage must be selected using the digital input (with specific set-up to enable the measure of a voltage – ref. G1, G2, G3, G4, G5, G6 par. 5.11)

NOTE: it is required that the secondary voltages of the different VT's must be the same.

Example:

U1 Ur U2 Uc
----------------

U3 Uc U4 OFF
-----------------

As function of the digital input, the SCK4N-D unit allow the paralleling command issue taking into consideration the voltage measured by the U2 transducer or the voltage measured by the U3 transducer. All VT's connected to U1, U2 and U3 must have the same secondary nominal voltage.

**D5 - PARALLELING (CLOSING) COMMAND LENGTH (programmable)**

Tcom k.kk s
----------------

**k.kk** length (seconds) of the command issued to close the circuit breaker.

The paralleling command (when pulse command mode is selected) will be issued activating the programmed output relay to close for **Tcom** seconds.

For the programmable values please refer to table A.

Example:

Tcom 0.20 s
----------------

## 5.7 Set-up VOLTAGE CHECK DEAD BUS - LT

### E1LT - VOLTAGE ABSENCE THRESHOLD (programmable)

U< n.nn xxxxxx V
---------------------

**n.nn:** threshold value expressed as Un  
**xxxxxx:** threshold value expressed as Volt

The overcome of the threshold means **absence of the voltage** (DEAD BUS). For the programmable values please refer to table A.

The SCK4N-D unit verifies that the **U<** threshold value must be programmed lower than the value **U> / 1.2**. If the condition is not verified, an error message will be displayed during the programming session (at CONFIRM programming – ref. 4.1).

### E2LT - E3LT - E4LT - FUNCTIONAL MODE SELECTION (programmable)

Ur> Uc< ccc
----------------

Ur< Uc> ccc
----------------

Ur< Uc< ccc
----------------

**ccc** ON - enabled functional mode  
OFF - disabled functional mode

Selection of the functional mode related to VOLTAGE CHECK - DEAD BUS paralleling operations (refer to paragraph 1.1).

More than functional mode can be enabled at the same time.

Example:

<b>E2LT</b> Ur> Uc< ON
------------------------------

<b>E3LT</b> Ur< Uc> OFF
-------------------------------

<b>E4LT</b> Ur< Uc< ON
------------------------------

If the **Uc** voltage is absent and the **Ur** voltage is present or the **Uc** and **Ur** voltages are both absent, the paralleling command will be issued.

### E5LT - TIME DELAY TO COMMAND ISSUE (programmable)

T1t IND xx.xx s
--------------------

Set-up of the time delay to the paralleling command issue (for safe operations to avoid command issue with unstable conditions of the network).

The time delay is definite time only. For the programmable values please refer to table A.

### E6LT - PARALLELING COMMAND MODE (programmable)

COM lt
vvvvvvvv

**vvvvvvvv**: IMPULSIV - pulse command (length **Tcom** seconds - ref. D5)  
CONTINUO - continuous command

With the CONTINUO selection the output relay of the SCK4N-D unit will remain activated (paralleling command) as long as the paralleling condition will be present.

### E7LT - ADDITIONAL TIME DELAY (programmable)

TAlt LT
xx.xx s

An additional time delay **TAlt** will increase the programmed time delay **TIt** (ref. E5LT) to obtain a total time delay to the command issue equals to **TIt+TAlt** seconds.

Please note that at least one of the digital inputs should be programmed to activate time delay function (ref. G1, G2, G3, G4, G5, G6 – paragraph 5.11).

For the programmable values please refer to table A.

### E8LT- DIGITAL INPUT ACTIVE ON ADDITIONAL TIME DELAY (not programmable)

TAlt LT
eeeeeee

It shows the digital input programmed to activate the additional time delay **TAlt**.

The parameter eeeeeeee can show one of the following values:

DISABLED	none of the digital inputs has been programmed to activate an additional time delay TAlt
DIG1	digital input DIG1 activates the TAlt delay
DIG2	digital input DIG2 activates the TAlt delay
DIG3	digital input DIG3 activates the TAlt delay
DIG4	digital input DIG4 activates the TAlt delay
DIG5	digital input DIG5 activates the TAlt delay
DIG6	digital input DIG6 activates the TAlt delay

More than one digital input can activate the same additional time delay (e.g. DIG 1,5).

Please note that to activate the additional time delay at least one of the digital inputs should be programmed (ref. G1, G2, G3, G4, G5, G6 - paragraph 5.11).

## 5.8 Set-up SYNCHRO-CHECK - PS

### E1PS - VOLTAGE DIFFERENCE THRESHOLD (programmable)

DUs< .uu
xxxxxx V

Set-up of the maximum voltage difference (as absolute value) between the voltage **Ur** and the voltage **Uc** that will allow the issue of the paralleling command (if the voltage difference is greater than the programmed value the paralleling command issue will be disabled).

**.uu**                    threshold value expressed as Un  
**xxxxxx**                threshold value expressed as Volt

If the **LT** (VOLTAGE CHECK - DAED BUS) mode is also enabled, the SCK4N-D unit will verify that the **DUs<** threshold value must be programmed lower than:

$$0.8 * (U> - U<)$$

If the condition is not verified, an error message will be displayed during the programming session (at CONFIRM programming - ref. 4.1).

For the programmable values please refer to table A.

### E2PS - SLIPPING THRESHOLD (programmable)

Ss<
a.aa %

Set-up of the maximum slipping (as absolute value) between the voltage **Ur** and the voltage **Uc** that will allow the issue of the paralleling command (if the slipping is greater than the programmed value the paralleling command issue will be disabled).

**a.aa**    maximum allowed slipping as % of the frequency

For the programmable values please refer to table A.

### E3PS - PHASE ANGLE THRESHOLD (programmable)

$\Phi$ s<
bb°

Set-up of the maximum phase angle (as absolute value) between the voltage **Ur** and the voltage **Uc** that will allow the issue of the paralleling command (if the phase angle is greater than the programmed value the paralleling command issue is disabled).

**bb**        maximum allowed phase angle (degree)

For the programmable values please refer to table A.

**E4PS - TIME DELAY TO COMMAND ISSUE (programmable)**

Tps IND xx.xx s
--------------------

Set-up of the time delay to the paralleling command issue (for safe operations to avoid command issue with unstable conditions of the network).

The time delay is definite time only. For the programmable values please refer to table A.

**E5PS - PARALLELING COMMAND MODE (programmable)**

COM ps vvvvvvvv
--------------------

**vvvvvvvv**: IMPULSIV - pulse command (length **Tcom** seconds - ref. D5)  
CONTINUO - continuous command

With the CONTINUO selection the output relay of the SCK4N-D unit will remain activated (paralleling command) as long as the paralleling condition will be present.

**E6PS - ADDITIONAL TIME DELAY (programmable)**

TApS PS xx.xx s
--------------------

An additional time delay **TApS** will increase the programmed time delay **Tps** (ref. E4PS) to obtain a total time delay to the command issue equals to **Tps+TApS** seconds.

Please note that at least one of the digital inputs should be programmed to activate time delay function (ref. G1, G2, G3, G4, G5, G6 - paragraph 5.11).

For the programmable values please refer to table A.

**E7PS - DIGITAL INPUT ACTIVE ON ADDITIONAL TIME DELAY (not programmable)**

TApS PS eeeeeee
--------------------

It shows the digital input programmed to activate the additional time delay **TApS**.

The parameter eeeeeee can show one of the following values:

DISABLED	none of the digital inputs has been programmed to activate an additional time delay <b>TApS</b>
DIG1	digital input DIG1 activates the <b>TApS</b> delay
DIG2	digital input DIG2 activates the <b>TApS</b> delay
DIG3	digital input DIG3 activates the <b>TApS</b> delay
DIG4	digital input DIG4 activates the <b>TApS</b> delay
DIG5	digital input DIG5 activates the <b>TApS</b> delay
DIG6	digital input DIG6 activates the <b>TApS</b> delay

More than one digital input can activate the same additional time delay (e.g. DIG 1,5).

Please note that to activate the additional time delay at least one of the digital inputs should be programmed (ref. G1, G2, G3, G4, G5, G6 - paragraph 5.11).

## 5.9 Set-up - SYNCHRONIZER - PA

### E1PA - VOLTAGE DIFFERENCE THRESHOLD (programmable)

DUa< .uu
xxxxxx V

Set-up of the maximum voltage difference (as absolute value) between the voltage **Ur** and the voltage **Uc** that will allow the issue of the paralleling command (if the voltage difference is greater than the programmed value the paralleling command will not be issued).

**.uu** threshold value expressed as Un  
**xxxxxx** threshold value expressed as Volt

If the **LT** (VOLTAGE CHECK - DAED BUS) mode is also enabled, the SCK4N-D unit verifies that the **DUa<** threshold value must be programmed lower than:

$$0.8 * (U> - U<)$$

If the condition is not verified, an error message will be displayed during the programming session (at CONFIRM programming - ref. 4.1)

For the programmable values please refer to table A.

### E2PA - SLIPPING THRESHOLD (programmable)

Sa<
a.aa %

Set-up of the maximum slipping (as absolute value) between the voltage **Ur** and the voltage **Uc** that will allow the issue of the paralleling command (if the slipping is greater than the programmed value the paralleling command will not be issued).

**a.aa** maximum allowed slipping as % of the frequency

For the programmable values please refer to table A.

The SCK4N-D unit will verify if the threshold value **Sa<** is higher than:

**1.2 \* Ss<** (slipping threshold PS - ref. **E2PS**) if the PS mode (Synchro-Check) is also enabled at the same time

**1.2 \* Sx<** (slipping threshold to force command issue to the speed governor - ref. **E12PA**)

If both conditions are not verified, an error message will be displayed during the programming session (at CONFIRM programming - ref. 4.1)

Example:

Sa< 0.80 %
---------------

### E3PA - E4PA - E5PA - VOLTAGE SLIPPING DERIVATIVE THRESHOLD AND RELATED PARAMETERS (programmable)

The voltage slipping derivative threshold is used to avoid paralleling command issue when the voltage slipping is changing too quickly therefore the command issue on the computed lead condition will not guarantee the circuit breaker closing on the synchronized condition.

E3PA	E4PA	E5PA
dSa< ccc Tk .rr s	Ks d.d %/s <sup>2</sup>	Tmnv k.kk s

Programming of the voltage slipping derivative threshold **dSa<** and its parameters to allow the SCK4N-D unit to compute it.

**ccc** ON - enabled function  
OFF - disabled function

**.rr** parameter **Tk** used in the computation of the maximum voltage slipping threshold (seconds) - suggested value 0.5 s

**d.d** parameter **Ks** (expressed as %/s<sup>2</sup>) used in the computation of the maximum voltage slipping threshold - suggested value 1 %/s<sup>2</sup>

**k.kk** operating time (closing delay) of the paralleling circuit breaker used in the computation of the maximum voltage slipping threshold (seconds)

$$|dSa/dt| < = Ks * (Tk - Tant) = Ks * (Tk - Tmnv - Tmis)$$

**Ks** programmable parameter - ref. **E4PA**

**Tk** programmable parameter

**Tmnv** circuit breaker operating time - programmable - ref. **E5PA**

**Tmis** 0.04 seconds - SCK4N-D unit measuring time

For the programmable values please refer to table A.

The SCK4N-D unit will verify if **Tk** is greater than **Tmnv** + 0.27 sec. If the condition is not verified, an error message will be displayed during the programming session (at CONFIRM programming - ref. 4.1).

Example:

E3PA	E4PA	E5PA
dSa< ON Tk .50 s	Ks 1.2 %/s <sup>2</sup>	Tmnv 0.15 s

$$|dSa/dt| < = Ks * (Tk - Tmnv - Tmis) = 0.37 \% / \text{sec}$$



with **Tk** greater than 0.42 seconds ( $T_{mnv} + 0.27$ )

### E6PA - TIME DELAY TO COMMAND ISSUE (programmable)

Tps IND xx.xx s
--------------------

Set-up of the time delay to the paralleling command issue (for safe operations to avoid command issue with unstable conditions of the network).

The time delay is definite time only. For the programmable values please refer to table A.

### E7PA - ADDITIONAL TIME DELAY (programmable)

TApa PA xx.xx s
--------------------

An additional time delay **TApa** will increase the programmed time delay **Tpa** (ref. E4PS) to obtain a total time delay to the command issue equals to **Tpa+TApa** seconds.

Please note that at least one of the digital inputs should be programmed to activate time delay function (ref. G1, G2, G3, G4, G5, G6 - paragraph 5.11)

For the programmable values please refer to table A.

### E8PA- DIGITAL INPUT ACTIVE ON ADDITIONAL TIME DELAY (not programmable)

TApa PA eeeeeee
--------------------

It shows the digital input programmed to activate the additional time delay **TApa**.

The parameter eeeeeeee can show one of the following values:

DISABLED	none of the digital inputs has been programmed to activate an additional time delay TApA
DIG1	digital input DIG1 activates the TApA delay
DIG2	digital input DIG2 activates the TApA delay
DIG3	digital input DIG3 activates the TApA delay
DIG4	digital input DIG4 activates the TApA delay
DIG5	digital input DIG5 activates the TApA delay
DIG6	digital input DIG6 activates the TApA delay

More than one digital input can activate the same additional time delay (e.g. DIG 1,5).

Please note that to activate the additional time delay at least one of the digital inputs should be programmed (ref. G1, G2, G3, G4, G5, G6 - paragraph 5.11)

**E9PA - E10PA - GENERATOR SPEED GOVERNOR COMMANDS (programmable)**

Enable/disable commands issue (AUM - accelerate, DIM - decelerate) to the generator speed governor and command length (seconds).

E9PA	E10PA
REG ccc	Treg e.ee s

**ccc** ON - enabled function  
OFF - disabled function

**e.ee** command length (seconds)

For the programmable values please refer to table A.

**E11PA - EXCESSIVE VOLTAGE SLIPPING THRESHOLD TO DISABLE COMMAND ISSUE TO THE SPEED GOVERNOR (programmable)**

Sm> ccc p.pp %
-------------------

**ccc** ON - enabled function  
OFF - disabled function

**p.pp** voltage slipping threshold

The SCK4N-D unit will verify if the threshold **Sm>** will be higher than the threshold **Sa<**.

If the condition is not verified, an error message will be displayed during the programming session (at CONFIRM programming - ref. 4.1)

For the programmable values please refer to table A.

Example:

Sm> ON 05.0 %
------------------

**E12PA - LOW VOLTAGE SLIPPING THRESHOLD TO FORCE THE ISSUE OF THE AUM - DIM COMMANDS TO THE SPEED GOVERNOR (programmable)**

When the function is enabled, if the measured voltage slipping is lower than the threshold **Sx<** and the phase angle between **Ur** and **Uc** voltages is greater than **Φx>** (see ref. E13PA) the SCK4N-D unit will issue forced AUM/DIM commands to avoid excessive long paralleling operations.

Sx< ccc a.aa %
-------------------

**ccc** ON - enabled function  
OFF - disabled function

**a.aa** low voltage slipping threshold value

The SCK4N-D unit will verify if the threshold value  $S_{x<}$  is lower than  $|S_{a<}| / 1.2$

If the condition is not verified, an error message will be displayed during the programming session (at CONFIRM programming - ref. 4.1).

For the programmable values please refer to table A.

Example:

$S_{x<}$ ON 0.05 %
-----------------------

### E13PA - HIGH PHASE-ANGLE DIFFERENCE THRESHOLD TO FORCE THE ISSUE OF THE AUM - DIM COMMANDS TO THE SPEED GOVERNOR (programmable)

$\Phi_{x>}$ bb °
---------------------

**bb** phase-angle threshold value (degrees)

The threshold is related to the minimum slipping threshold  $|S_{x<}|$  (ref. E12PA). For the programmable values please refer to table A.

Example:

$\Phi_{x>}$ 45 °
---------------------

### E14PA - TIME DELAY BETWEEN TWO AUM - DIM COMMANDS (programmable)

Ti eeeee xxx.xx s
----------------------

Time delay between the issue of two consecutive **AUM / DIM** commands.

**Parameter Ti eeeee** time delay curve selection

INDIP	definite time delay
DIP-I	inverse time delay (dependent time)
DIP-E	exponential time delay (dependent time)

The time delay formulas are the followings:

- definite time delay  $T_I$
- inverse time delay  $T = \frac{K}{|B|}$
- exponential time delay  $T = K * 2^{(1-|B|)}$

where  $B = \frac{|Sa|}{|S|}$

|Sa| module of the programmed voltage slipping threshold |Sa|< (ref. E2PA)

|S| module of the measured voltage slipping

If a time dependent curve is selected, the value of the minimum time delay **Tim** between two consecutive command will be programmable (ref. E15PA) to guarantee the correct acquisition of commands by the speed governor.

For the programmable values of Ti and K please refer to table A.

Examples:

Ti DIP=I
002.00 s

Ti INDIP
005.00 s

### **E15PA - MINIMUM TIME DELAY BETWEEN TWO AUM - DIM COMMANDS (programmable)**

Tim IND
xx.xx s

Programming of the minimum time delay between the issue of two commands AUM or DIM.

The time delay is time definite only. For the programmable values please refer to table A.

The SCK4N-D unit will verify if the value **Tim** is lower than **Ti** (ref. E14PA). If the condition is not verified, an error message will be displayed during the programming session (at CONFIRM programming - ref. 4.1).

Example:

Tim IND
05.00 s

### **E16PA - TIME DELAY BETWEEN FORCED AUM-DIM COMMANDS ISSUE (programmable)**

Tx IND
xx.xx s

Programming of the time delay between two AUM or DIM commands issued (forced issue) by overcoming of both thresholds  $|Sx|<$  and  $|\Phi x|>$  to avoid the system stand-by condition with high phase-angle difference and with negligible or very low voltage slipping.

The time delay is time definite only. For the programmable values please refer to table A.

The SCK4N-D unit will verify if the value **Tx** is higher than **Tim** (ref. E15PA). If the condition is not verified, an error message will be displayed during the programming session (at CONFIRM programming - ref. 4.1).

Example:

```
Tx IND
06.00 s
```

## 5.10 Output relays programming (fig. 2)

The session allows to program the activation of the output relays R1, R2, R3 or R4.

Equivalent information and set-up related to relay R1 is available for the relays R2, R3 and R4 just changing the relay identification.

### F1 - OUTPUT RELAY R1 QUIESCENT STATUS (programmable)

```
R1
NORM xxx
```

Programming of the R1 relay status when no START / TRIP conditions are activated.

NORM OFF: normally de-energized (energized status on activation)  
 NORM ON: normally energized (de-energized status on activation)

### F2 - OUTPUT RELAY R1 ACTIVATION ON THRESHOLD U>> (programmable)

```
R1 U>>
xxxxxx
```

Programming of the R1 output relay activation (TRIP/NONE) on the programmed threshold U>>.

The parameter xxxxx is selectable as the following:

TRIP output relay R1 activation when one of the measured voltages is over the programmed threshold level U>>  
 NONE no activations related to threshold U>>

### F3 ÷ F6 - OUTPUT RELAY ACTIVATION ON THRESHOLDS Ur>, Ur<, Uc> and Uc< (programmable)

F3	F4	F5	F6
R1 Ur> xxxxxxxx	R1 Ur< xxxxxxxx	R1 Uc> xxxxxxxx	R1 Uc< xxxxxxxx

Programming of the R1 output relay activation on the START condition of the programmed thresholds **Ur>**, **Ur<**, **Uc>**, **Uc<** on the measured voltages (presence or absence of the reference voltage **Ur** or of the controlled voltage **Uc**).

The parameter xxxxx is selectable as the following:

START: output relay R1 activation when one of the measured voltages is over the programmed threshold level **U>** (Ur> and Uc>) or **U<** (Ur< and Uc<)  
 NONE: no activation related to thresholds **U>** or **U<**

**F7 - F8 - OUTPUT RELAY ACTIVATION ON THRESHOLDS DUs< and DUa< (programmable)**

F7	F8
R1 DUs< xxxxxxxx	R1 DUa< xxxxxxxx

Programming of the R1 output relay activation on the START condition of the programmed threshold **DUs<** (voltage difference between the voltages **Ur** and **Uc** when enabled the **PS - Synchro-check operating mode**) or of the programmed threshold **DUa<** (voltage difference between the voltages **Ur** and **Uc** when enabled the **PA - Synchronizer operating mode**).

The parameter xxxxx is selectable as the following:

START	output relay R1 activation when the threshold <b>DUs&lt;</b> or <b>DUa&lt;</b> is overcame
NONE	no activation related to thresholds <b>DUs&gt;</b> or <b>DUa&lt;</b>

**F9 - OUTPUT RELAY ACTIVATION FOR PARALLELING COMMAND ISSUE (programmable)**

R1 COM xxxxxxxx
--------------------

Programming of the R1 output relay to deliver the paralleling command to the circuit breaker (after the programmed time delay TIt, Tps or Tpa).

The parameter xxxxxxxx is selectable as the following:

START	command issue on paralleling condition
NONE	no activation

**F10 - F11 - F12 - OUTPUT RELAY ACTIVATION ON PARALLELING CONDITION (programmable) - START CONDITION (without time delay)**

F10	F11	F12
R1 AVTlt xxxxxxxx	R1 AVTps xxxxxxxx	R1 AVTpa xxxxxxxx

Programming of the R1 output relay activation when the paralleling condition appears (without any time delay - START condition).

The parameter xxxxxxxx is selectable as the following:

START	relay activation on the paralleling condition
NONE	no activation

**F13 - OUTPUT RELAY ACTIVATION ON |Sm|> THRESHOLD (programmable)**

R1 Sm>
xxxxxxxx

Programming of the R1 output relay activation on the START condition of the programmed threshold **Sm>** (accelerate/decelerate command issue inhibition for excessive voltage slipping) - **PA** operating mode only

The parameter xxxxxxxx is selectable as the following:

START	output relay R1 activation when the threshold <b>Sm&gt;</b> is overcome
NONE	no activation related to threshold <b>Sm&gt;</b>

**F14 - F15 - OUTPUT RELAY PROGRAMMING TO ISSUE THE AUM/DIM COMMANDS TO THE GENERATOR SPEED GOVERNOR (programmable)**

<b>F14</b>	<b>F15</b>
R1 AUM xxxxxxxx	R1 DIM xxxxxxxx

Programming of the output relay R1 to issue commands **AUM** (accelerate) or **DIM** (decelerate) to the speed governor of the generator.

The parameter xxxxxxxx is selectable as the following:

START	output relay R1 activation to issue AUM or DIM command
NONE	no activation enabled to issue AUM / DIM commands

NOTE: a relay must be programmed for **AUM** command and another relay for **DIM** command.

**F16 - TEST OF OUTPUT RELAY R1**

TEST R1
xxxxxxxx

See paragraph 4.4

**5.11 Digital inputs function programming (fig. 2)**

For each digital input one of the following functions are selectable:

- a) additional time delay on circuit breaker closing command
- b) ON/OFF unit operation (all operating modes)
- c) ON/OFF specific operating mode
- d) ON / OFF threshold
- e) disable issue of AUM/DIM commands
- f) selection of voltages measurement channel
- g) temporary enable of the unit operations

- h) STATUS function (recording of measures on external command)
- i) pilot wire fault monitoring (only DIG2 monitors DIG1).

When the function of more than one digital input refers to a threshold, the priority will be the following:

- a) OF selection (threshold or operating mode disabled) has the priority on TA function (additional time delay) or ON ABIL function (temporary operating enable)
- b) the ALL selection (ALL the thresholds) has the priority on single threshold selection.

### G1 - DIGITAL INPUT DIG1 SET-UP (programmable)

DIG1 cc
xxxxxxxx

Programming of the function related to digital input channel 1 (DIG1).

**Parameter cc:** programming of the condition that activates the function related to digital input DIG1; the condition is selectable between HI and LO.

**Parameter xxxxxx:** programming of the function related to digital input DIG1; the following functions are selectable:

NONE	no functions active related to digital input DIG1
TA LT	additional delay on paralleling command issue – mode LT
TA PS	additional delay on paralleling command issue – mode PS
TA PA	additional delay on paralleling command issue – mode PA
TA TUTTI	additional delay on paralleling command issue – all modes
ON ABIL	all unit operations enabled temporary
OF U1	measuring channel U1 disabled
OF U2	measuring channel U2 disabled
OF U3	measuring channel U3 disabled
OF U4	measuring channel U4 disabled
OF Ur>	operating mode LT on Ur> and Uc< conditions disabled
OF Uc>	operating mode LT on Uc> and Ur< conditions disabled
OF Ur,c>	operating mode LT on Ur< and Uc< conditions disabled
OF LT	LT operating mode disabled
OF PS	PS operating mode disabled
OF PA	PA operating mode disabled
OF TUTTI	all operating modes disabled
OF dSa<	threshold  dSa < disabled
OF Sm>	threshold  Sm > disabled
OF Sx<	threshold  Sx < disabled
OF REG	command AUM / DIM disabled
STATO	activation of status function (see paragraph 1)



**G2 - DIGITAL INPUT DIG2 SET-UP (programmable)**

DIG2 cc
xxxxxxxx

Programming of the function related to digital input channel 2 (DIG2); the selections available are the same as presented for DIG1 (ref. G1) plus the following:

MONITOR                      activation of pilot wire monitor function.

**G3 ÷ G6 - DIGITAL INPUT DIG3 SET-UP (programmable)**

<b>G3</b>	<b>G4</b>	<b>G5</b>	<b>G6</b>
DIG3 cc	DIG4 cc	DIG5 cc	DIG6 cc
xxxxxxxx	xxxxxxxx	xxxxxxxx	xxxxxxxx

Programming of the function related to digital input channel DIG3, DIG4, DIG5 and DIG6; the selections available are the same as presented for DIG1 (ref. G1).

**5.12 Special function programming (fig. 2)**

It allows the temporary operation enable of the SCK4N-D unit following a **DIGITAL INPUT COMMAND** (paragraph 5.11 – ref. G1, G2, G3, G4, G5 and G6 - ON ABIL selection).

When the function is enabled, if the parallel condition is already present the SCK4N-D unit will be able to issue the paralleling command to the circuit breaker as soon as the digital input status is acknowledged.

The enable condition for the unit operation will be active for a programmable time delay **Tabil** after the change of the digital input status to operation disabled.

When the time delay expires, the SCK4N-D unit will not be able to issue commands to the circuit breaker even when the paralleling conditions are present.

<b>H1</b>	<b>H2</b>
ABILITAZ	Tabil
TEMP ccc	nnn S

**ccc**    ON - enabled function  
          OFF - disabled function

**nnn**    time length of unit operation, programmable from 1 to 999 s

Example:

<b>H1</b>	<b>H2</b>
ABILITAZ	Tabil
TEMP ON	060 S

### 5.13 Signals visualization (fig. 3)

#### L1 ÷ L4 - MEASURING CHANNEL STATUS

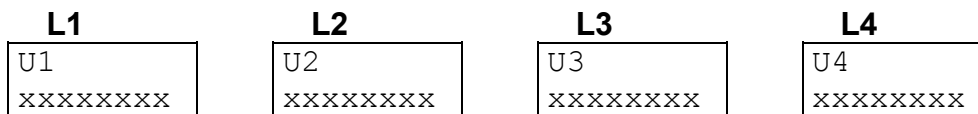

The status of each measuring channel is shown.

Each display presents the measuring channel identification (U1, U2, U3, U4 – corresponding to the SCK4N-D transducers) and the related function (ref. set-up D3 - D4 - par. 5.6); the function can be:

Uc	channel measuring the controlled voltage
Ur	channel measuring the reference voltage
OFF	channel programmed disabled (ref. D3 - D4 - par. 5.6)
OFF_DIG	channel temporary disabled by a digital input (ref. G1, G2, G3, G4, G5, G6 - par. 5.11)

Examples:



#### L5 ÷ L10 - OPERATING MODE STATUS

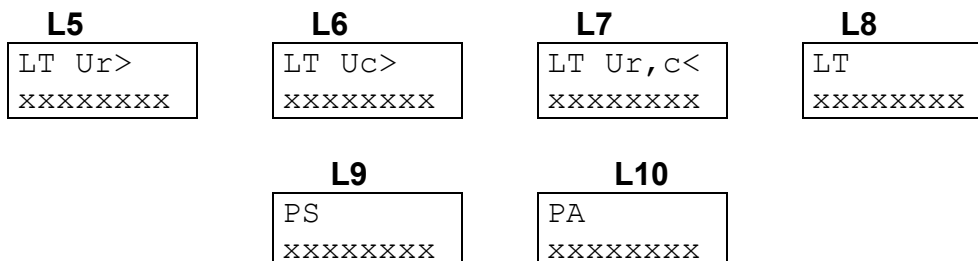

The status of the actual operating modes is shown as the following:

ON	enabled operating mode (ref. A2 paragraph 5.)
OFF	disabled operating mode (ref. A2 paragraph 5.)
OFF_DIG	operating mode temporary disabled by digital input status (ref. G1, G2, G3, G4, G5, G6 - par. 5.11)
OFF TEMP	operating mode temporary disabled (function ON ABIL ref. G1, G2, G3, G4, G5, G6 - par. 5.11 and ref. H1 par. 5.12)

Examples:

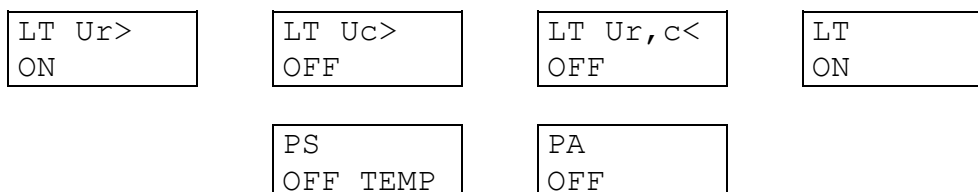

The SCK4N-D unit is always enabled to issue the paralleling command to the circuit breaker in the VOLTAGE CHECK - DEAD BUS operating mode when the reference voltage is present (absence of the controlled voltage) and the SCK4N-D unit will be enabled from digital input (temporary enabled for a defined time length – ref. H2) to issue the paralleling command when the SYNCHRO CHECK paralleling condition is verified (therefore when the controlled voltage is present and synchronised with the reference voltage).

### L11 ÷- L15 - THRESHOLDS STATUS

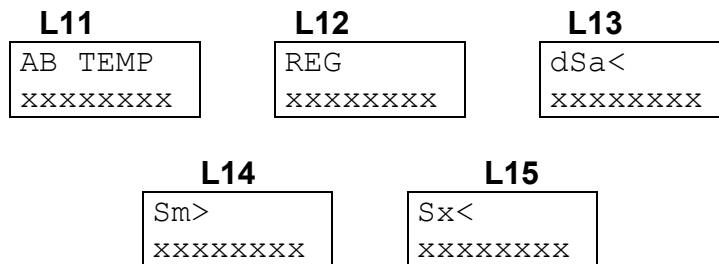

The status of the following functions is presented:

- |            |  |
|------------|--|
| <b>L11</b> | unit temporary operative - ref. H1, paragraph 5.12   |
| <b>L12</b> | AUM/DIM command issue to speed governor - ref. E9PA, par. 5.9                                    |
| <b>L13</b> | minimum voltage slipping derivative threshold - ref. E3PA, par. 5.9                              |
| <b>L14</b> | excessive voltage slipping threshold for AUM/DIM command issue inhibition - ref. E11PA, par. 5.9 |
| <b>L15</b> | too low voltage slipping threshold for AUM/DIM forced command issue - ref. E12PA, par. 5.9       |

The status of each command or threshold can be:

- |          |  |
|----------|--|
| ON       | enabled command or threshold   |
| OFF      | disabled command or threshold  |
| OFF_DIG  | command or threshold temporary disabled by digital input status (ref. G1, G2, G3, G4, G5, G6 - par. 5.11) – except for ref. L11            |
| OFF TEMP | operating mode temporary disabled under function ON ABIL (ref. G1, G2, G3, G4, G5, G6 - par. 5.11 and ref. H1 par. 5.12) only for ref. L11 |

### M1 - M2 - OUTPUT RELAY STATUS

The actual status of each output relay is displayed; for each relay the following information is displayed:

- relay identification (R1, R2, R3, R4)
- relay status (ON - activated, OFF - non activated)

Note: that ON/OFF does not necessary mean energized or de-energized (see ref. M1).

Example:

M1	M2
R1 ON	R3 OFF
R2 OFF	R4 ON

## N1 - N2 - N3 - DIGITAL INPUT STATUS

The actual status of each digital input is displayed. For each digital input the following information is presented:

- digital input identification (DIG1, DIG2, DIG3, DIG4, DIG5 and DIG6)
- digital input status (HI or LO)

## P1 ÷ P9 - MEASUREMENT DISPLAY

The actual values of the measured or computed parameters are displayed; the following information is displayed:

P1	P2	P3	P4	P5
Ur = Uq Uc = Uq	Ur x.xx yyyyyy V	Fr dd.dd Hz	Uc x.xx yyyyyy V	Fc dd.dd Hz
P6	P7	P8	P9	
DU ±x.xx ±yyyyyyV	S ±f.ff %	Φ ±bbb°	dS ±.ee %/s	

When a parameter is not measured (as function of the active operating mode) the information is not shown.

- P1** Uq shows the measuring transducer (U1, U2, U3, U4) referred to measures of Ur (reference voltage) and Uc (controlled voltage).
- P2** measured voltage Ur (reference voltage) expressed as Un and volt.
- P3** measured frequency Fr (related to reference voltage) expressed as Hertz.
- P4** measured voltage Uc (controlled voltage) expressed as Un and volt.
- P5** measured frequency Fc (related to reference voltage) expressed as Hertz.
- P6** difference voltage between Ur (reference voltage) and Uc (controlled voltage) expressed as Un and volt.
- P7** voltage slipping between Ur (reference voltage) and Uc (controlled voltage) expressed as % of Fr
- P8** phase angle between Ur (reference voltage) and Uc (controlled voltage) expressed as degree.
- P9** voltage slipping derivative between Ur (reference voltage) and Uc (controlled voltage) expressed as degree per second.

## 5.14 Events (fig. 3)

On the display are shown the memorized information related to the last 6 event like:

- paralleling command issue
- temporary operation enable of the SCK4N-D unit (ref. to ON TEMP selection – par. 5.12)
- power on of the SCK4N-D unit
- status (memorization of measured parameter on external command)

The 6 events are recorded and identified with a progressive number from 1 to 6; the more recent event shows a lower number.

### Q1 - EVENT NUMBER

```
E1
cccccccc
```

The index E1, E2 ... E6 identifies the memorized event.

The parameter **cccccccc** gives information on the kind of event and it can show one of the following values:

NONE	no event memorized
MODO LT	paralleling command issue - operating mode LT
MODO PS	paralleling command issue - operating mode PS
MODO PA	paralleling command issue - operating mode PA
U>>	event on trip threshold U>>
ON TEMP	temporary SCK4N-D unit activation from digital input
STATUS	information recorded on external command
POWER ON	switch-on of the protection relay (auxiliary power)

For the events NONE and POWER ON no other information is presented: for the other events the following displays give more detailed information on the event.

### Q2 - FUNCTIONAL MODE (only LT operating mode and threshold U>>)

```
E1 ppp
nnnnnnnn
```

**ppp** identification of the operating mode **LT**

**nnnnnnnn** functional mode related to the LT operating mode (**Ur> Uc<**, **Ur< Uc>**, **Ur< Uc<**) or functional mode enabled when the U>> threshold operates

### Q3 - Q4 - VOLTAGE THRESHOLD U>> and U>

Q3	Q4
1 U>> x.xx Un	E1 U> x.xx Un

**x.xx** value of the programmed thresholds **U>>** and **U>** (see par. 5.6) expressed as Un

**Q5 - VOLTAGE THRESHOLD  $U<$  (only LT operating mode)**

E1 $U<$ x.xx Un
--------------------

**x.xx** value of the programmed threshold  $U<$  (see par. 5.7) expressed as **Un**

**Q6 - Q7 - Q8 - THRESHOLDS RELATED TO SYNCHRO-CHECK OPERATING MODE (only PS operating mode)**

Q6	Q7	Q8
E1 $DUs<$ x.xx Un	E1 $Ss<$ a.aa %	E1 $\Phi S<$ bb°

**x.xx** programmed minimum voltage difference  $DUs<$  threshold (see par. 5.8 - ref. E1PS) expressed as **Un**

**a.aa** programmed minimum voltage slipping  $Ss<$  threshold (see par. 5.8 - ref. E2PS) expressed as percentage of the reference voltage frequency

**bb** programmed minimum phase angle  $\Phi s<$  threshold (see par. 5.8 - ref. E3PS) expressed as degree

**Q9 - Q10 - THRESHOLDS RELATED TO SYNCHRONISING OPERATING MODE (only PA operating mode)**

Q9	Q10
E1 $DUa<$ x.xx Un	E1 $Sa<$ a.aa %

**x.xx** programmed minimum voltage difference  $DUa<$  threshold (see par. 5.9 - ref. E1PA) expressed as **Un**

**a.aa** programmed minimum voltage slipping  $Sa<$  threshold (see par. 5.9 - ref. E2PA) expressed as percentage of the reference voltage frequency

**Q11 - Q12 - Q13 - Q14 - PARAMETERS FOR VOLTAGE SLIPPING DERIVATIVE THRESHOLD RELATED TO SYNCHRONISER OPERATING MODE (only PA mode)**

Q11	Q12	Q13	Q14
E1 $Tmnv$ k.kk S	E1 $dSa>$ ccc	E1 $Ks$ d.d %/s <sup>2</sup>	E1 $Tk$ k.kk s

**k.kk** programmed circuit breaker operating time  $Tmnv$  (see par. 5.9 - ref. E5PA) expressed as seconds

**ccc** enable/disable (ON/OFF) voltage slipping derivative threshold (see par. 5.9 - ref. E3PA)

**d.d** programmed  $Ks$  parameter (see par. 5.9 - ref. E4PA) expressed as %/s<sup>2</sup>

**k.kk** programmed **Tk** parameter (see par. 5.9 - ref. E3PA) expressed as seconds

#### Q15 - PARALLELING COMMAND LENGTH

E1 Tcom k.kk s
-------------------

**k.kk** paralleling command length (pulse command mode) or minimum paralleling command length (continuous command mode).

#### Q16 - PARALLELING COMMAND MODE (only LT and PS operating mode)

E1 COM xxxxxxx
-------------------

**xxxxxx** paralleling command mode of the circuit breaker (IMPULSIV, CONTINUO) ref. E6PS - par. 5.8

#### Q17 - SPEED GOVERNOR COMMANDS STATUS (only PA operating mode)

E1 REG ccc
---------------

**ccc** ON/OFF status of AUM/DIM commands to the speed governor on event

#### Q18 - Q19 - MAXIMUM VOLTAGE SLIPPING THRESHOLD TO DISABLE AUM/DIM COMMAND ISSUE TO THE SPEED GOVERNOR (only PA operating mode)

Q18	Q19
E1 Sm> ccc	E1 Sm> aa.a %

**ccc** ON/OFF status of the maximum voltage slipping threshold to disable AUM/DIM command issue to the speed governor

**aa.a** programmed threshold value **Sm>** (see par. 5.9 - ref. E11PA) expressed as % of the nominal frequency

#### Q20 - Q21 - Q22 - MINIMUM VOLTAGE SLIPPING THRESHOLD FOR FORCED COMMAND ISSUE TO SPEED GOVERNOR (only PA operating mode)

Q20	Q21	Q22
E1 Sx< ccc	E1 Sx< a.aa %	E1 Φx> bb°

**ccc** ON/OFF status of the minimum voltage slipping threshold for forced AUM/DIM command issue to speed governor.

**a.aa** programmed threshold **Sx<** (see par. 5.9 - ref. E12PA) expressed as % of the reference voltage frequency

**bb** programmed threshold value **Φx>** (see par. 5.9 - ref. E13PA) expressed as degree

**Q23 - ACTIVATED OUTPUT RELAYS**

```
E1 RELAY
nnnnnnn
```

It shows the list of the output relay activated at the event (threshold trip, paralleling command issue etc.).

Examples:

```
E1 RELAY
1, 3, 4
```

```
E3 RELAY
1, 4
```

When no output relays have been activated the following message will be displayed:

```
E1 RELAY
NONE
```

**Q24 - TOTAL TIME DELAY TO PARALLELING COMMAND ISSUE**

```
E1 T-Tot
www.ww s
```

It is shown the total delay to the paralleling command issue; the time delay is inclusive of the programmed additional time delay and of the time required to wait for the  $\Phi = \Phi_{ant}$  condition (only with the PA operating mode - ref. paragraph 1.3).

When the event is memorized on external command (STATUS), the message N/A (Not Applicable) is shown instead of the number of seconds.

```
E1 T-Tot
N/A
```

**Q25 - DIGITAL CHANNELS RELATED TO MEMORIZED EVENT**

```
E1 DIG
1, 3, 4
```

The list of the digital inputs related to the memorized event is displayed (STATUS function or paralleling command issue).

If no digital inputs were activated, the message NONE is displayed.

**Q26 - Q27 - Q28 - Q29 - Q30 - Q31 - Q32 - MEMORIZED MEASURED PARAMETERS****Q26**

```
E1 Ur Uq
y.yy Un
```

**Q27**

```
E1 Fr
zz.zz Hz
```

**Q28**

```
E1 Uc Uq
y.yy Un
```

**Q29**

```
E1 DU
±y.yy Un
```

**Q30**

```
E1 S
±f.ff %
```

**Q31**

```
E1  $\Phi$ 
±hhh°
```

**Q32**

```
E1 dS
±r.rr%/s
```



The value of the measured parameters on the event (status, paralleling command issue, thresholdtrip etc.) are shown.

**q** measuring transducer (1, 2, 3, 4) related to **Ur** (reference voltage measurement) and **Uc** (controlled voltage measurement).

**y.yy** **Ur** and **Uc** voltages and voltage difference between **Ur** and **Uc** expressed as **Un**

**zz.zz** value of the frequency of the voltage **Ur** expressed as **Hz**

**f.ff** value of the voltage slipping between **Ur** and **Uc** expressed as % of the voltage reference frequency

**hhh** value of the phase angle between **Ur** and **Uc** expressed as degree

**r.rr** value of the voltage slipping derivative between **Ur** and **Uc** expressed as %/s

### Q33 - Q34 - Q35 - Q36 - Q37 - Q38 - DIGITAL INPUTS STATUS ON EVENT

E1 DIG1 vv	E1 DIG2 vv	E1 DIG3 vv
E1 DIG4 vv	E1 DIG5 vv	E1 DIG6 vv

The status of the digital inputs at the event are displayed. The parameter **vv** can assume the value HI or LO.

### Q39 - Q40 - DATE AND TIME OF THE EVENT

E1 Date dd/mm/yy	E1 Time hh:mm:ss
---------------------	---------------------

The date and time of the event are showed

## 5.15 Trip counters (fig. 3)

In this section are displayed the total and partial counters of the output relay activation related to the **U>>** threshold TRIP conditions or to the paralleling command issue to the circuit breaker (for each operating mode) and the numbers of programming sessions with the date and time of the last confirmed programming session.

The total counters, the number of confirmed programming sessions and the date and time of the last confirmed programming session are not modifiable or resettable; the information related to the last programming session are used to control unauthorized access.

The partial counter can be modified following the standard set-up procedure for parameters as described at paragraph 4.2; the partial counters are immediately modified in the memory (the recorded values are immediately resetted without the need of the programming confirmation).

**R1 ÷ R12 - TRIP COUNTERS**

For the U>> threshold and for each operating and functional mode the partial (P) and total (T) counters are displayed.

The counters are identified by the threshold (U>>) or by the operating mode (LT Ur>, LT Uc>, LT Ur,c<, PS, PA); only the programmed active operating mode are displayed.

Example:

<b>R1</b>	<b>R2</b>
LT Ur> P cccc	LT Ur> T cccc

When the value exceed 9999 the counter starts again from 0000. The partial counters are modifiable in the range from 0000 to 9999 following the standard set-up procedure.

**R13 ÷ R15 - TOTAL PROGRAMMING SESSIONS AND DATE/TIME OF THE LAST PROGRAMMING SESSION**

TOT PRG eeee	DATE PRG dd/mm/yy	TIME PRG hh:mm:ss
-----------------	----------------------	----------------------

Display of the number of confirmed programming sessions (from the factory set-up) and the date and time of the last confirmed programming session.

## 6 INSTALLATION

### 6.1 Supplied kit

**RK VERSION - 19" rack installation** (the proper rack is supplied by SEB)

- SCK4N-D unit with rear socket
- transparent front panel for rack installation
- n° 2 blister with items 1-2-3-4-5

**MR VERSION – mini rack installation**

- SCK4N-D unit with rear socket
- transparent front panel for rack flush mounting installation
- mini rack for SCK4N-D unit
- n° 2 blister with items 1-2-3-4-5

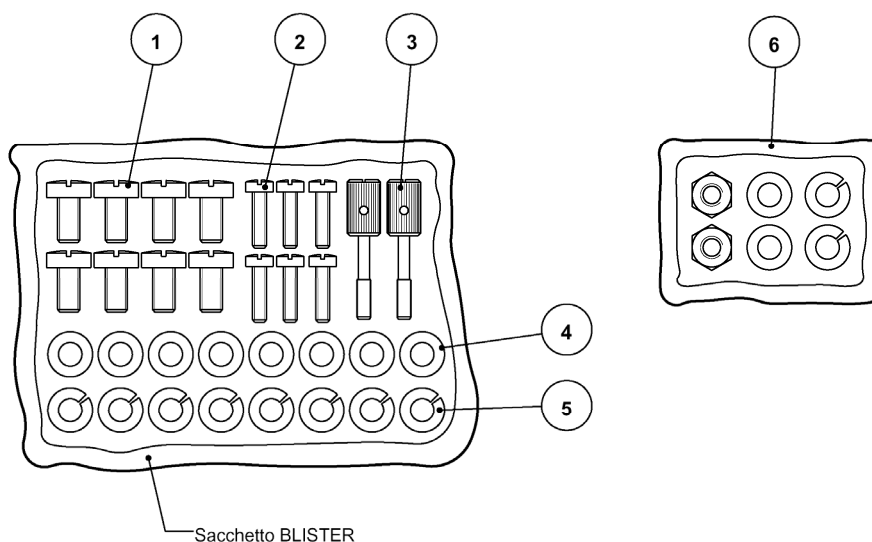

- 1) n° 8 screws to fix wire terminals of current circuits (NOT USED)
- 2) n° 4 screws to fix the relay rear socket on the 19" rack (or on the two brackets for flush mounting) and n° 2 screws to fix (optionally) the protection relay on the front of the 19" rack
- 3) n° 2 knobs to fix the transparent front panel
- 4) n° 8 washers to be used to fix wire current terminals (NOT USED)
- 5) n° 8 growers to be used to fix wire current terminals (NOT USED)
- 6) small items to fix brackets on the cabinet (not applicable)

The knobs to fix the transparent front panel must be screwed through the front panel itself; the operation will create a screw thread in the plastic material to prevent knob missing.

NOTE: The items related to current inputs are the standard supplied items with all SIGMA-N protection relays but for the SCK4N-D unit they are not used.

## 6.2 Cabling

### Voltage circuits

It is suggested to terminate the voltage wirings using plug terminals.

Minimum suggested wire cross section: 1,5 mm<sup>2</sup>

With reference to the insertion diagram in the next page, the voltages measured by the protection relay have the following matching:

U1	terminals 1 - 3 terminals 2 - 3	voltages with Un programmed from 190 to 380 V voltages with Un programmed from 0 to 125 V
U2	terminals 6 - 8 terminals 7 - 8	voltages with Un programmed from 190 to 380 V voltages with Un programmed from 0 to 125 V
U3	terminals 11 - 13 terminals 12 - 13	voltages with Un programmed from 190 to 380 V voltages with Un programmed from 0 to 125 V
U4	terminals 16 - 18 terminals 17 - 18	voltages with Un programmed from 190 to 380 V voltages with Un programmed from 0 to 125 V

### Other circuits (output relays etc.)

It is suggested to terminate the wiring using plug terminals.

Minimum suggested wire cross section: 1,5 mm<sup>2</sup>

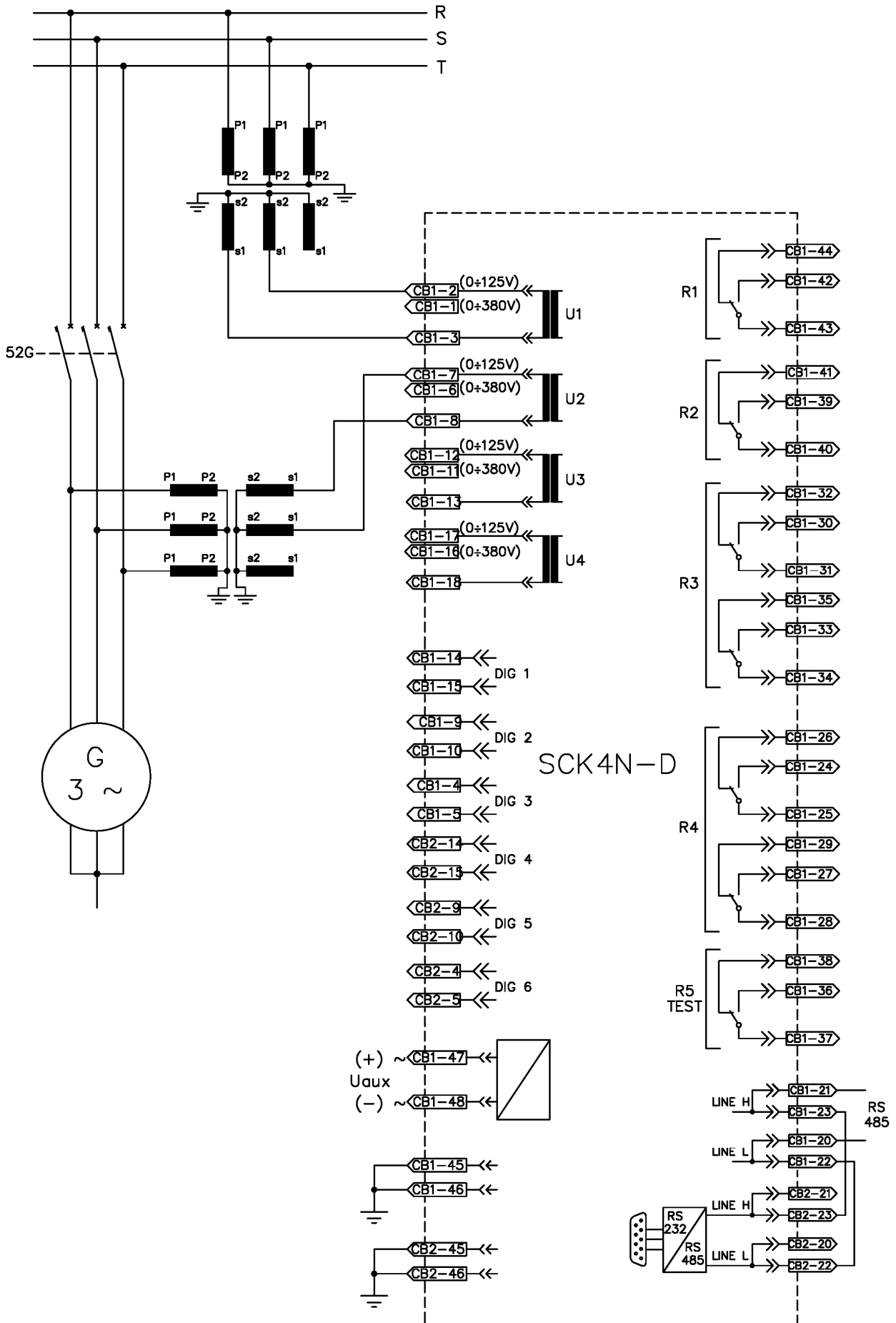

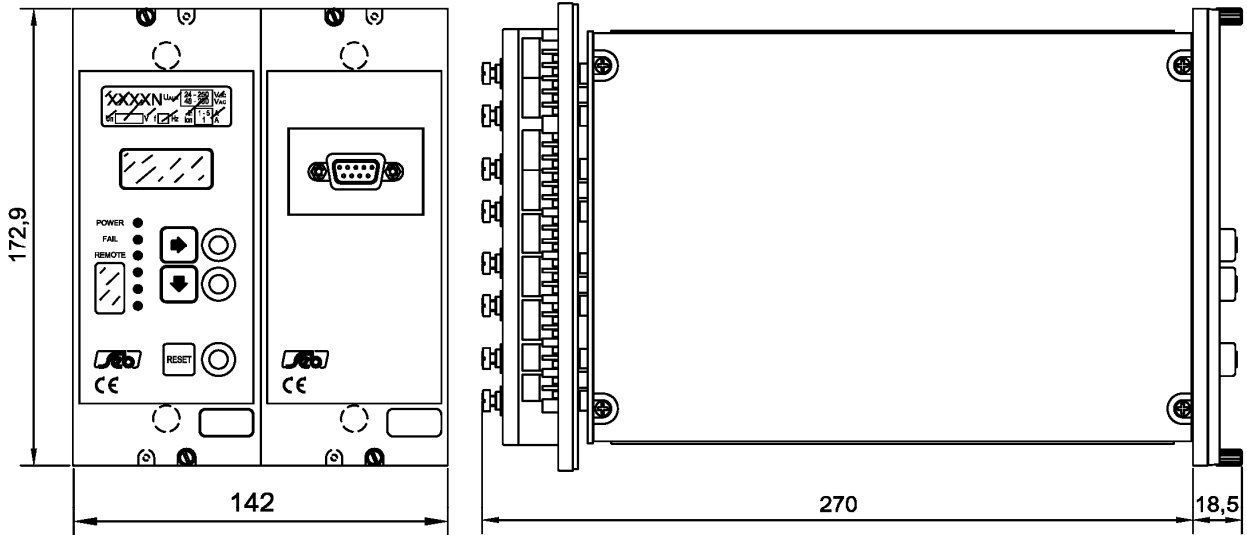

Dimensioni  
meccaniche  
Case outlines

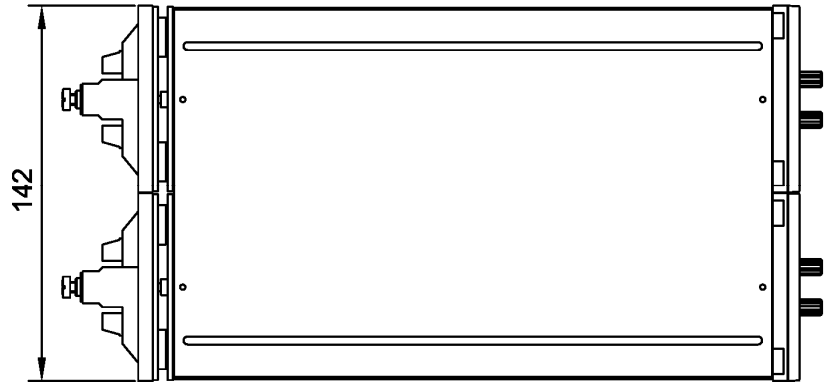

Dima montaggio da incasso  
Flush mounting panel cut - out

Dimensioni frontali mini-rack per incasso  
Mini-rack front sizes (flush mounting)  
198.2 x 177 (4U) mm.

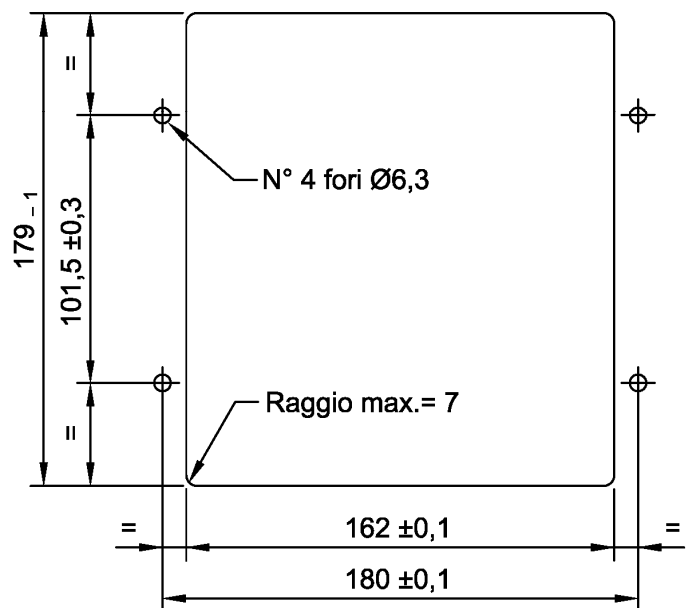

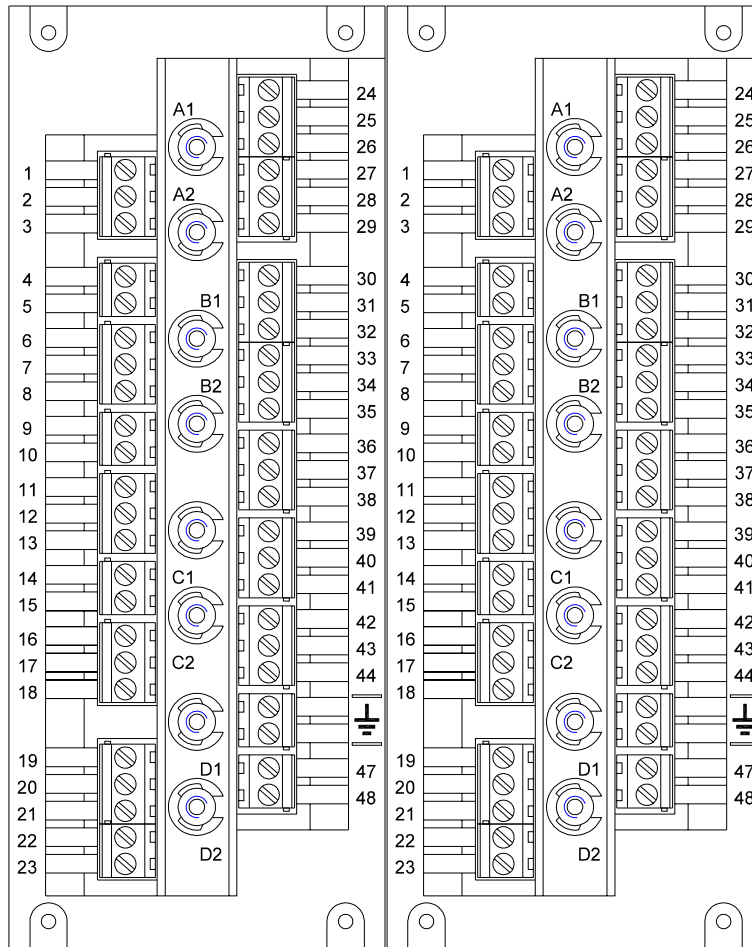

CB2

CB1

Rear view

**6.3 Relays R3 and R4 - Signaling / Command set-up**

The SCK4N-D unit is supplied with R3 and R4 relays configured as **SIGNALING RELAYS**, with 2 change-over output contacts with breaking capability equals to 0.2 A at 110 Vdc, L/R = 40 ms, 100000 operations.

Each R3 and R4 relay can be configured as **COMMAND RELAY** with 1 change-over output contact with breaking capability equals to 0.5 A at 110 Vdc, L/R = 40 ms, 100000 operations.

The new configuration is obtained with the following cabling:



## 6.4 RS485 serial communication port

The SCK4N-D unit presents an insulated serial interface RS485 half-duplex that allow the multi-drop connection up to 31 protection units.

The transmission speed is automatically selected between 300 to 9600 bauds and the protocol is ASCII-HEX; the documentation related to the protocol is freely available on request.

It is suggested to use a shielded twisted pair AWG22; terminal 19 (not connected internally) can be used for shields connections.

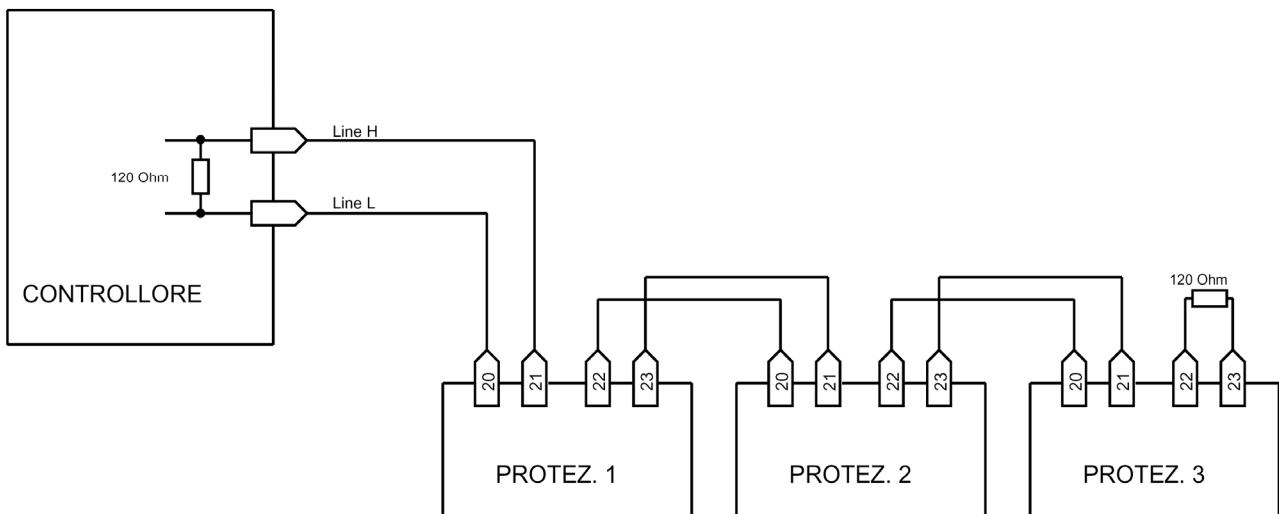

It is suggested to terminate the serial line with a resistance  $120 \Omega$ ,  $1/4 \text{ W}$ .



## 7 TECHNICAL CHARACTERISTICS

### Measuring inputs

Rated voltage (Un) programmable	57.73 - 63.50 - 72.16 - 100 - 110 V 125 - 190 - 220 - 230 - 380 - 400 V
Thermal withstand continuously	2 Un
Thermal withstand for 1 s	2 Un
Rated frequency	50 / 60 Hz
Primary VT's voltage	1 - 999999 V

### Output contacts ratings

Number of relays (note 1)	4 + 1
Rated current	5 A
Rated voltage	250 V
Contact configuration	change over
Breaking capability (note 2)	
- tripping relays (R1, R2)	0.5 A
- signaling relays (R3, R4, R5) (note 3)	0.2 A
Mechanical life	> 10 <sup>6</sup>

### Digital inputs

Number of inputs	6
External control voltage	as Uaux
Typical current (sink)	2 mA

### Data transmission

Standard	RS-485 half duplex
Communication protocol	MOD-BUS ASCII
Transmission speed	300 - 9600 baud selectable
Optional	fibre optic module

### Auxiliary supply

Range	24 ÷ 320 Vdc ± 20% 48 ÷ 230 Vac ± 20%
Frequency (Vac)	47 ÷ 63 Hz
Burdens (min/max)	5 / 10 W

### Environmental conditions

Operation	- 10 / +60 °C
Transport and storage	- 25 / +80 °C
Relative humidity (without condensation)	< 95%
Protection degree for flush mounting (optional)	IP 52 (IP 54)
Weight	2.5 kg

- Note 1) The additional relay R5 is controlled by self-test program  
 Note 2) Breaking capability at 110 Vdc, L/R 40 ms, 100.000 operations  
 Note 3) The output contacts of R3 and R4 relays can be configured as signalling or tripping relays

## 8 TABLES

### Table A Settings

Functional Mode	Threshold / parameter		Setting	Risolut.
LT - PS - PA	<b>U&gt;</b>	Voltage presence	0.30 ÷ 2.00 Un	0.01 Un
	<b>U&gt;&gt;</b>	Overvoltage (function inhibition)	0.30 ÷ 2.00 Un	0.01 Un
	<b>Tcom</b>	Closing command length	0.10 ÷ 0.99 s	0.01 s
LT	<b>U&lt;</b>	Voltage absence	0.01 ÷ 0.99 Un	0.01 Un
	<b>Tlt</b>	Time delay on command issue	0.02 ÷ 99.99 s	0.01 s
	<b>TAIt</b>	Additional delay on command issue	0.00 ÷ 99.99 s	0.01 s
PS	<b>DU&lt;</b>	Voltage difference	0.01 ÷ 0.99 Un	0.01 Un
	<b>Ss&lt;</b>	Voltage slipping	0.02 ÷ 0.20 %	0.01 %
	<b>Φs&lt;</b>	Phase-angle between voltages	0° ÷ 90°	1°
	<b>Tps</b>	Time delay on command issue	0.02 ÷ 99.99 s	0.01 s
	<b>TAps</b>	Additional delay on command issue	0.00 ÷ 99.99 s	0.01 s
PA	<b>DUa&lt;</b>	Voltage difference	0.01 ÷ 0.99 Un	0.01 Un
	<b>Sa&lt;</b>	Voltage slipping	0.04 ÷ 2.00 %	0.01 %
	<b>Tpa</b>	Time delay on command issue	0.02 ÷ 99.99 s	0.01 s
	<b>TApa</b>	Additional delay on command issue	0.00 ÷ 99.99 s	0.01 s
	<b>dSa&gt;</b>	Voltage slipping derivative $dSa< = Ks * (Tk - Tmnv - 0.04) \% / s$	ON / OFF	- - -
	<b>Ks</b>	Programmable constant	0.8 ÷ 9.9 %/s <sup>2</sup>	0.1 %/s <sup>2</sup>
	<b>Tk</b>	Time base	0.30 ÷ 0.99 s	0.01 s
	<b>Tmnv</b>	Circuit breaker operating time	0.02 ÷ 0.59 s	0.01 s
	<b>AUM / DIM Commands</b>			
	<b>Treg</b>	Commands length	0.10 ÷ 9.99 s	0.01 s
	<b>Ti</b>	Time delay between 2 command	0.05 ÷ 99.99 s	0.01 s
	<b>Tim</b>	Minimum time delay between 2 successive commands (time definite)	0.05 ÷ 99.99 s	0.01 s
		Time dependent curve selection	I , E	- - -
	<b>k</b>	Characteristic time constant	1 ÷ 200 s	1 s
	<b>Forced command issue</b>			
	<b>Sx&lt;</b>	Too low voltage slipping	0.02 ÷ 0.20 %	0.01 %
	<b>Φx&gt;</b>	High phase-angle difference	0° ÷ 90°	1°
	<b>Tx</b>	Time delay between commands	0.05 ÷ 99.9 s	0.01 s
	<b>Command inhibition</b>			
	<b>Sm&gt;</b>	Excessive voltage slipping	OFF/ 0.50 ÷ 30.0 %	0.1 %



**SEB DIVISIONE ELETTRONICA E SISTEMI - UFFICIO COMMERCIALE**

Via Fratelli Ceirano, 19 - 10024 MONCALIERI (TO)

**tel.** +39 011 6474893 - **fax** +39 011 0432996

web: [www.seb-barlassina.it](http://www.seb-barlassina.it)

mail to: [servizio-clienti@seb-barlassina.it](mailto:servizio-clienti@seb-barlassina.it)